

Overview

The Piezoelectric Haptic Modules (Film Flex Assembled Actuators) are revolutionary, next-generation flexible haptics actuator technology with the unique ability to provide localized, bodily sensations and tactile effects currently unavailable with any other product in the market. These versatile actuators can be used in a broad range of applications including AR/VR, gaming controllers, as well as in visionary products of the future that leverage human-computer interaction.

This is made possible by the thin form factor, ideal size and flexibility of the actuators.

With these Piezoelectric Haptic Modules the haptic skin technology designers can add the sense of touch to the surface of products providing:

- localized, independent sensations that enhance user experience,
- natural, organic, authentic touch sensations,
- programmable, customizable effects providing a unique range of sensations.

Applications

Products with hand contact:

- AR (Augmented Reality) and VR (Virtual Reality)
- Remote control
- Gaming controller
- Medical controller
- Smart textiles
- Mouse
- User interface capacitive touch surface

Products with lips contact:

- Musical instrument (mouth piece)
- Medical equipment

Benefits

- Extremely thin and flexible - enabling them to be conformally embedded into a variety surfaces for many applications to provide high quality haptic feedback
- Multi-location effects - whereby multiple actuators can be applied to different locations of the same surface and vibrated in a desired order to deliver a plurality of feedback approaches that combine pattern recognition and effect recognition.
- Wide frequency range provides haptic feedback - programmable haptic feedback that feels natural, providing a rich user experience
- Providing a natural sense of touch
- Increasing sense of realism and better tactile feedback
- Enhancing user satisfaction
- RoHS and REACH compliant

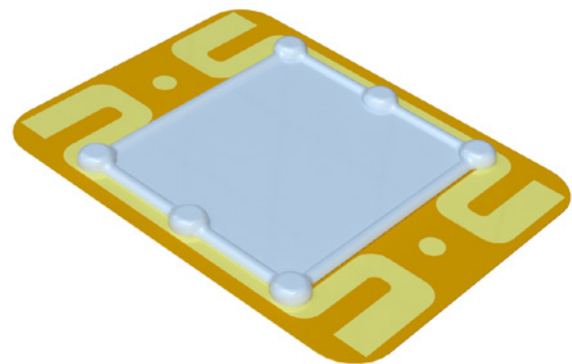

Ordering Information

FFAA	14	19	212	1	1	L
Series	Width (mm)	Length (mm)	Voltage (V_{pp})	Actuator Version	Flex Version	Packaging Code
FFAA	14 = 14.1	19 = 18.5	212	1 = V1	1 = See drawing below	L = Tray

Dimensions in mm

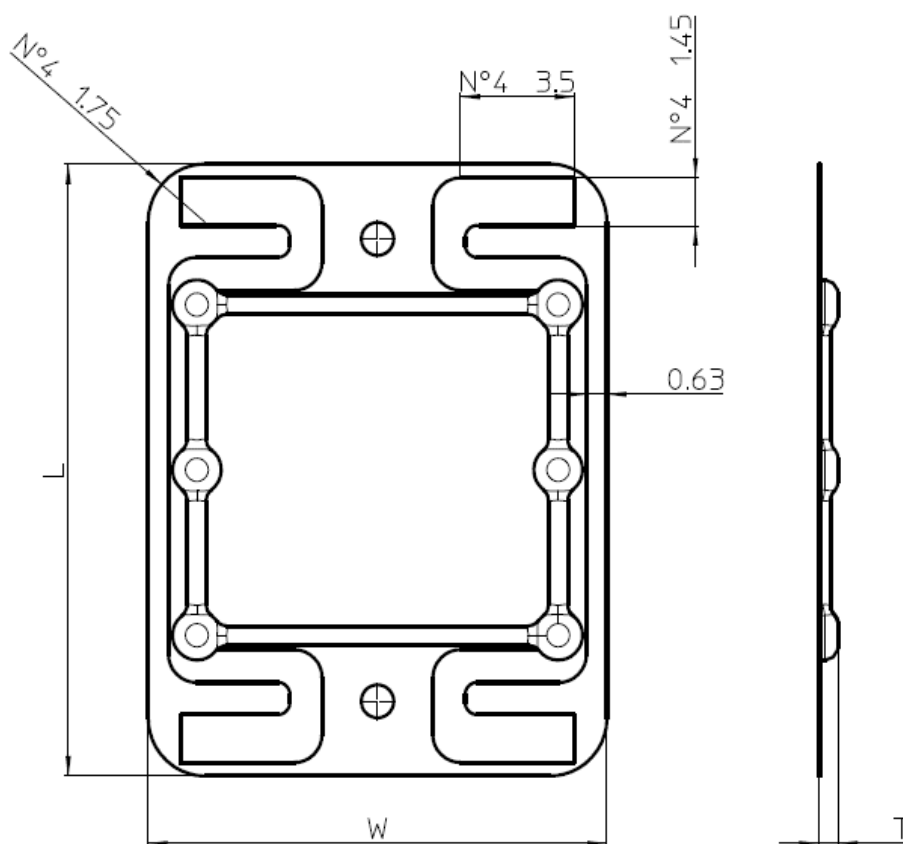

Part Number	Dimensions (mm)		
	W	L	T
FFAA141921211L	14.1 ±0.2	18.5 ±0.2	0.6 ±0.1

Environmental Compliance

All KEMET Piezoelectric Haptic Film Modules are RoHS and REACH compliant.



Performance Characteristics

Part Number	Parameter	Symbol	Minimum	Maximum	Description
FFAA141921211L	Stimulus signal voltage	V_{PP}	0 V	212 V	Peak-to-peak voltage, all peaks of positive sign
	Frequency	Hz	0 Hz	500 Hz	Voltage frequency
	Peak Inrush Current	I_{IN}	-	200 mA	1 msec pulse width
	Slew Rate	dV/dt	-	0.2 V/ μ sec	
	Storage Temperature	T_S	-20°C	+90°C	
	Assembly Temperature	T_{ASS}	-	+100°C	
	Operating Temperature	T_A	0°C	+60°C	

These Modules can also be offered in a Demo Kit version on RQ, please contact your KEMET sales representative for more information.

Out of Plane Displacement for Sinusoidal Stimulation at 150 Hz

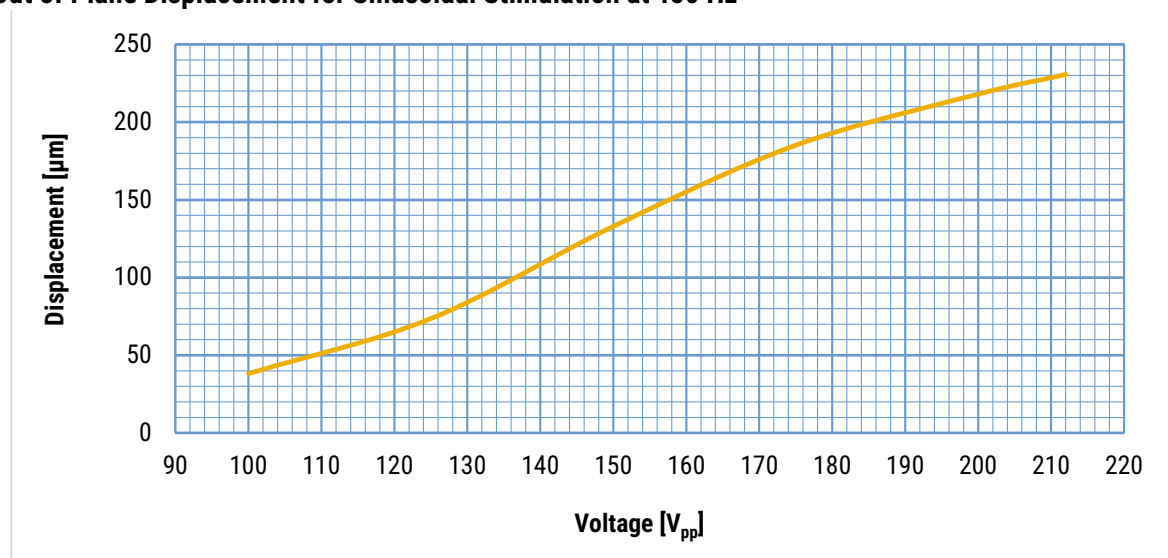

Environmental Test Data

Storage		
Parameter	Test and Environmental Conditions	Post-Test Result
High Temperature	90°C for 24 hours, non-operating test	Meets the performance characteristics
Low Temperature	-20°C for 24 hours, non-operating test	Meets the performance characteristics
Long Term	25°C, ±5°C for 1 year storage in dry conditions	Meets the performance characteristics
	(< 30% R.H.), non-operating test	

Operating Environment		
Parameter	Test and Environmental Conditions	Post-Test Result
Room Temperature	1 M cycles of 1 second on/3 seconds off; 212 V _{pp} 150 Hz 25°C, ±5°C and 50% R.H.	Displacement drop at end of life of -20% (typical)

Non-Operating Environment		
Parameter	Test and Environmental Conditions	Post-Test Result
Thermal Cycling	Modified MIL-STD JESD22 Method JA-104: -20°C <=> +90°C; 5 minute dwell; 1,000 cycles	Meets the performance characteristics

Packaging

Part Number	Packaging Type	Pieces per Tray	Pieces per Box
FFAA141921211L	Tray	45	180

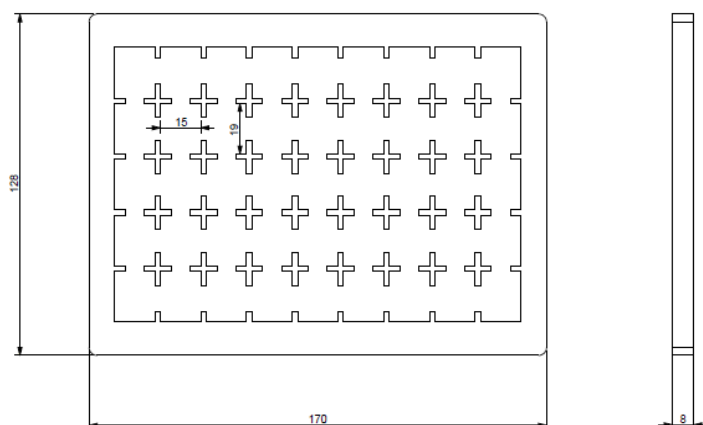

Handling Precautions

Precautions to be taken when using Piezoelectric Haptic Modules (Film Flex Assembled Actuators)

Material selection, installation and activation of Piezoelectric Haptic Modules should be decided upon by users according to the applications. For proper evaluation and decision, products should be tested repeatedly in both realistic and abnormal operating conditions.

- Do NOT use near flammable gas or solvent as alcohol, thinner, benzene, gasoline, propane gas due to risk of explosion or fire.
- Do NOT clean with flammable solvent such as alcohol, thinner and benzene due to risk of explosion or fire.
- CAREFULLY apply bending or other mechanical stress as it may change the performance characteristics.
- CAREFULLY apply bending stress during product handling or assembling process.
- Do NOT remodel FFAA Modules to fit into the design.
- Do NOT reuse FFAA modules that have been removed from a assembly unit.
- Do NOT operate or store in dusty high temperature environment, near fire, under strong light or sunshine, in the air containing salt or oil.
- KEMET recommends that maximum storage temperature does not exceed 90°C and maximum storage humidity does not exceed 50% relative humidity and atmospheres should be free of chlorine and sulfur bearing compounds. Temperature fluctuations should be minimized to avoid condensation on the parts.
- KEMET recommends to keep the product inside the dry-pack until its use.

Integration of the Piezoelectric Haptic Modules (Film Flex Assembled Actuators)

Please contact your KEMET sales representative for more information about the Piezoelectric Haptic Modules integration.

KEMET Electronics Corporation Sales Offices

For a complete list of our global sales offices, please visit www.kemet.com/sales.

Disclaimer

YAGEO Corporation and its affiliates do not recommend the use of commercial or automotive grade products for high reliability applications or manned space flight.

All product specifications, statements, information and data (collectively, the "Information") in this datasheet are subject to change. The customer is responsible for checking and verifying the extent to which the Information contained in this publication is applicable to an order at the time the order is placed. All Information given herein is believed to be accurate and reliable, but it is presented without guarantee, warranty, or responsibility of any kind, expressed or implied.

Statements of suitability for certain applications are based on KEMET Electronics Corporation's ("KEMET") knowledge of typical operating conditions for such applications, but are not intended to constitute – and KEMET specifically disclaims – any warranty concerning suitability for a specific customer application or use. The Information is intended for use only by customers who have the requisite experience and capability to determine the correct products for their application. Any technical advice inferred from this Information or otherwise provided by KEMET with reference to the use of KEMET's products is given gratis, and KEMET assumes no obligation or liability for the advice given or results obtained.

Although KEMET designs and manufactures its products to the most stringent quality and safety standards, given the current state of the art, isolated component failures may still occur. Accordingly, customer applications which require a high degree of reliability or safety should employ suitable designs or other safeguards (such as installation of protective circuitry or redundancies) in order to ensure that the failure of an electrical component does not result in a risk of personal injury or property damage.

Although all product-related warnings, cautions and notes must be observed, the customer should not assume that all safety measures are indicated or that other measures may not be required.

When providing KEMET products and technologies contained herein to other countries, the customer must abide by the procedures and provisions stipulated in all applicable export laws and regulations, including without limitation the International Traffic in Arms Regulations (ITAR), the US Export Administration Regulations (EAR) and the Japan Foreign Exchange and Foreign Trade Act.

KEMET is a registered trademark of KEMET Electronics Corporation.