

Overview

The PHE841 series is constructed of metallized polypropylene film encapsulated with self-extinguishing resin in a box of material that meets the requirements of UL 94 V-0.

Applications

For worldwide use as electromagnetic interference (EMI) suppression filter in across-the-line applications requiring X1 safety classification.

Not for use in series with the mains.

Benefits

- Approvals: ENEC, UL, cUL
- Class X1 (IEC 60384-14)
- Rated voltage: 330 VAC 50/60 Hz
- Capacitance range: 0.01 – 2.2 μ F
- Lead spacing: 10 – 37.5 mm
- Capacitance tolerance: \pm 20%, option \pm 10%
- Climatic category 40/100/56/B, IEC 60068-1
- Tape & Reel in accordance with IEC 60286-2
- RoHS compliant and lead-free terminations
- Operating temperature range of -40°C to +100°C
- 100% screening factory test at 3,000 VDC
- Self-healing properties

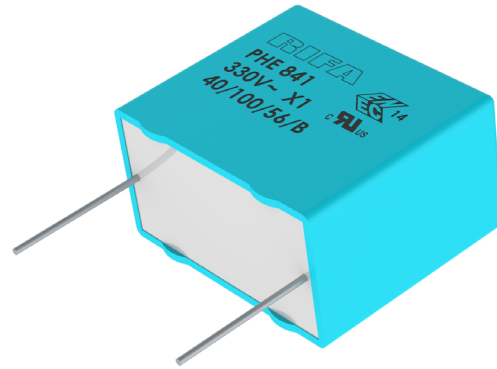

Customer Part Number

PHE841	E	D	6100	M	R06L2
Series	Rated Voltage (VAC)	Lead Spacing (mm)	Capacitance Code (pF)	Capacitance Tolerance	Packaging
X1, Metallized Polypropylene	E = 330	A = 10 B = 15 D = 22.5 F = 27.5 R = 37.5	The last three digits represent significant figures. The first digit specifies the total number of digits.	K = \pm 10% M = \pm 20%	See Ordering Options Table

KEMET Internal Part Number

F	841	D	H	104	M	330	C
Capacitor Class	Series	Lead Spacing (mm)	Size Code	Capacitance Code (pF)	Capacitance Tolerance	Rated Voltage (VAC)	Packaging
F = Film	X1, Metallized Polypropylene	A = 10 B = 15 D = 22.5 F = 27.5 R = 37.5	See Dimension Table	The first two digits represent significant figures. The third digit specifies number of zeros.	K = \pm 10% M = \pm 20%	330 = 330	See Ordering Options Table

Ordering Options Table

Lead Spacing Nominal (mm)	Type of Leads and Packaging	Lead Length (mm)	KEMET Part Number (Insert at 14th character)	Legacy Part Number (Insert into the appropriate PN section)
10	Standard Lead and Packaging Options			
	Bulk (Bag) – Short Leads	6 +0/-1	C	R06
	Bulk (Bag) – Long Leads	17 +0/-1	A	R17
	Other Lead and Packaging Options			
	Tape & Reel (Standard Reel)	H ₀ = 18.5 ±0.5	L	R17T0
	Tape & Reel (Large Reel)	H ₀ = 18.5 ±0.5	P	R17T1
15	Standard Lead and Packaging Options			
	Bulk (Bag) – Short Leads	6 +0/-1	C	R06
	Bulk (Bag) – Long Leads	17 +0/-1	A	R17
	Other Lead and Packaging Options			
	Bulk (Bag) – Maximum Length Leads	30 +5/-0	ALW0L	R30
	Tape & Reel (Standard Reel)	H ₀ = 18.5 ±0.5	L	R17T0
	Tape & Reel (Large Reel)	H ₀ = 18.5 ±0.5	P	R17T1
22.5	Standard Lead and Packaging Options			
	Bulk (Tray) – Short Leads	6 +0/-1	C	R06L2
	Other Lead and Packaging Options			
	Tape & Reel (Standard Reel)	H ₀ = 18.5 ±0.5	L	R17T0
	Tape & Reel (Large Reel)	H ₀ = 18.5 ±0.5	P	R17T1
27.5	Standard Lead and Packaging Options			
	Bulk (Tray) – Short Leads	6 +0/-1	C	R06L2
	Other Lead and Packaging Options			
	Tape & Reel (Large Reel)	H ₀ = 18.5 ±0.5	P	R17T1
37.5	Standard Lead and Packaging Options			
	Bulk (Tray)–Short Leads	6 +0/-1	C	R06L2

Metallized Polypropylene Film EMI Suppression Capacitors

PHE841, Class X1, 330 VAC, 100°C

Dimensions – Millimeters

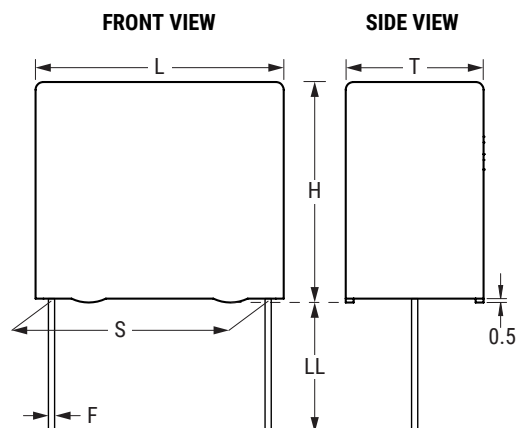

KEMET Size Code	Legacy Size Code	S		T		H		L		F	
		Nominal	Tolerance	Nominal	Tolerance	Nominal	Tolerance	Nominal	Tolerance	Nominal	Tolerance
AH	A02	10.0	±0.4	4.5	+0/-0.5	10.5	+0/-0.5	13.0	+0/-0.5	0.6	±0.05
AK	A03	10.0	±0.4	5.0	+0/-0.5	11.0	+0/-0.5	13.0	+0/-0.5	0.6	±0.05
AP	A04	10.0	±0.4	6.0	+0/-0.5	12.0	+0/-0.5	13.0	+0/-0.5	0.6	±0.05
BD	B04	15.0	±0.4	5.5	+0/-0.5	10.5	+0/-0.5	18.0	+0/-0.5	0.8	±0.05
BE	B05	15.0	±0.4	5.5	+0/-0.5	12.5	+0/-0.5	18.0	+0/-0.5	0.8	±0.05
BG	B15	15.0	±0.4	6.0	+0/-0.5	12.0	+0/-0.5	18.0	+0/-0.5	0.8	±0.05
BJ	B10	15.0	±0.4	6.5	+0/-0.5	12.5	+0/-0.5	18.0	+0/-0.5	0.8	±0.05
BL	B06	15.0	±0.4	7.5	+0/-0.5	14.5	+0/-0.5	18.0	+0/-0.5	0.8	±0.05
BM	B12	15.0	±0.4	8.0	+0/-0.5	15.0	+0/-0.5	18.0	+0/-0.5	0.8	±0.05
BQ	B11	15.0	±0.4	8.5	+0/-0.5	16.0	+0/-0.5	18.0	+0/-0.5	0.8	±0.05
BV	B14	15.0	±0.4	9.5	+0/-0.5	17.5	+0/-0.5	18.0	+0/-0.5	0.8	±0.05
DD	D13	22.5	±0.4	6.5	+0/-0.5	14.5	+0/-0.5	26.0	+0/-0.5	0.8	±0.05
DH	D14	22.5	±0.4	8.0	+0/-0.5	16.0	+0/-0.5	26.0	+0/-0.5	0.8	±0.05
DM	D15	22.5	±0.4	9.0	+0/-0.5	18.5	+0/-0.5	26.0	+0/-0.5	0.8	±0.05
DT	D16	22.5	±0.4	11.0	+0/-0.5	21.5	+0/-0.5	26.0	+0/-0.5	0.8	±0.05
DF	D17	22.5	±0.4	7.0	+0/-0.5	16.5	+0/-0.5	26.0	+0/-0.5	0.8	±0.05
DR	D18	22.5	±0.4	10.5	+0/-0.5	19.0	+0/-0.5	26.0	+0/-0.5	0.8	±0.05
DY	D19	22.5	±0.4	15.5	+0/-0.5	24.5	+0/-0.5	26.0	+0/-0.5	0.8	±0.05
FK	F03	27.5	±0.4	13.5	+0/-0.7	23.0	+0/-0.7	31.5	+0/-0.7	0.8	±0.05
FE	F11	27.5	±0.4	10.5	+0/-0.7	20.5	+0/-0.7	31.5	+0/-0.7	0.8	±0.05
FG	F12	27.5	±0.4	11.5	+0/-0.7	22.5	+0/-0.7	31.5	+0/-0.7	0.8	±0.05
FM	F13	27.5	±0.4	14.5	+0/-0.7	24.5	+0/-0.7	31.5	+0/-0.7	0.8	±0.05
FR	F14	27.5	±0.4	17.5	+0/-0.7	28.0	+0/-0.7	31.5	+0/-0.7	0.8	±0.05
FS	F15	27.5	±0.4	19.0	+0/-0.7	29.0	+0/-0.7	31.5	+0/-0.7	0.8	±0.05
FV	F16	27.5	±0.4	21.0	+0/-0.7	30.0	+0/-0.7	31.5	+0/-0.7	0.8	±0.05
RF	R05	37.5	±0.4	13.0	+0/-0.7	24.0	+0/-0.7	41.0	+0/-0.7	1.0	±0.05
RH	R04	37.5	±0.4	15.0	+0/-0.7	26.0	+0/-0.7	41.0	+0/-0.7	1.0	±0.05
RK	R02	37.5	±0.4	16.5	+0/-0.7	32.0	+0/-0.7	41.0	+0/-0.7	1.0	±0.05
RM	R03	37.5	±0.4	19.0	+0/-0.7	36.0	+0/-0.7	41.0	+0/-0.7	1.0	±0.05
RP	R06	37.5	±0.4	21.0	+0/-0.7	38.0	+0/-0.7	41.0	+0/-0.7	1.0	±0.05

Note: See the Ordering Options Table for lead length (LL) options.

Performance Characteristics

Dielectric	Polypropylene film			
Plates	Metal layer deposited by evaporation under vacuum			
Winding	Non-inductive type. Series design.			
Leads	Tinned wire			
Protection	Plastic case, thermosetting resin-filled. Box material is solvent-resistant and flame-retardant according to UL94 V-0.			
Rated Voltage V_R	330 VAC 50/60 Hz			
Capacitance Range	0.01 – 2.2 μF			
Capacitance Values	E6 series (IEC 60063)			
Capacitance Tolerance	$\pm 20\%$ standard, $\pm 10\%$ option			
Operating Temperature Range	-40°C to 100°C			
Rated Temperature	100°C			
Climatic Category	40/100/56/B IEC 60068-1			
Approvals	ENEC, UL, cUL			
Related Documents	EN/IEC 60384-14:2005, UL 60384-14, CAN/CSA E60384-14:09			
Dissipation Factor ($\tan\delta$)	Maximum Values at $+23^\circ\text{C}$			
	Frequency	$C \leq 0.1 \mu\text{F}$	$0.1 \mu\text{F} < C \leq 1 \mu\text{F}$	$C > 1 \mu\text{F}$
	1 kHz	0.1%	0.1%	0.1%
	10 kHz	0.2%	0.4%	0.8%
	100 kHz	0.6%	-	-
Test Voltage Between Terminals	The 100% screening factory test is carried out at 3,000 VDC. The voltage level is selected to meet the requirements in applicable equipment standards. All electrical characteristics are checked after the test. Do not repeat this test, as there is a risk of damaging the capacitor. KEMET is not liable for any failures if the test has been repeated.			
Resonance Frequency	Tabulated Self-resonance Frequencies f_o (See Table 1 – Ratings & Part Number Reference)			
Insulation Resistance	Measured at $+25^\circ\text{C} \pm 5^\circ\text{C}$, according to IEC 60384-2			
	Minimum Values Between Terminals			
	$C \leq 0.33 \mu\text{F}$	$C > 0.33 \mu\text{F}$		
	$\geq 30,000 \text{ M}\Omega$	$\geq 10,000 \text{ M}\Omega \cdot \mu\text{F}$		
In DC Applications	Recommended voltage $\leq 1,000 \text{ VDC}$			

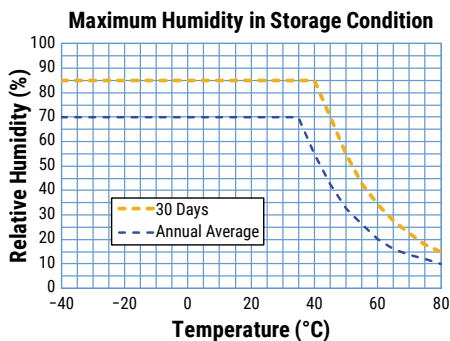

Environmental Test Data

Test	IEC Publication	Procedure
Endurance	IEC 60384-14:2005	1.25 x V _R VAC 50 Hz, once every hour increase to 1,000 VAC for 0.1 second, 1,000 hours at upper rated temperature
Vibration	IEC 60068-2-6 Test Fc	3 directions at 2 hours each 10 – 55 Hz at 0.75 mm or 98 m/s ² No visible damage. No open or short circuit.
Bump	IEC 60068-2-29 Test Eb	1,000 bumps at 390 m/s ² No visible damage. No open or short circuit.
Change of Temperature	IEC 60068-2-14 Test Na	Upper and lower rated temperature 5 cycles No visible damage.
Active Flammability	IEC 60384-14:2005	V _R + 20 surge pulses at 4 kV (pulse every 5 seconds)
Passive Flammability	IEC 60384-14:2005	IEC 60384-1, IEC 60695-11-5 Needle Flame Test
Damp Heat Steady State	IEC 60068-2-78 Test Cab	+40°C and 90 – 95% RH, 56 days

Environmental Compliance

All KEMET EMI capacitors are RoHS compliant.



Approvals

Certification Body	Mark	Specification	File Number
IMQ S.p.A.		EN/IEC 60384-14	CA08.00254
UL		UL 60384-14 and CAN/CSA E60384-14	E73869

Metallized Polypropylene Film EMI Suppression Capacitors
PHE841, Class X1, 330 VAC, 100°C

Table 1 – Ratings & Part Number Reference

Capacitance Value (µF)	Box Code	Maximum Dimensions in mm			Lead Spacing (S)	f _o (MHz)	dV/dt (V/µs)	KEMET Part Number	Legacy Part Number
		T	H	L					
0.01	A02	4.5	10.5	13	10	11	100	PHE841EA5100(1)(2)	F841AH103(1)300(2)
0.012	A03	5	11	13	10	10	100	PHE841EA5120(1)(2)	F841AK123(1)300(2)
0.015	A03	5	11	13	10	9.4	100	PHE841EA5150(1)(2)	F841AK153(1)300(2)
0.018	A04	6	12	13	10	8.7	100	PHE841EA5180(1)(2)	F841AP183(1)300(2)
0.022	A04	6	12	13	10	8.1	100	PHE841EA5220(1)(2)	F841AP223(1)300(2)
0.01	B04	5.5	10.5	18	15	10	100	PHE841EB5100(1)(2)	F841BD103(1)300(2)
0.012	B04	5.5	10.5	18	15	9.4	100	PHE841EB5120(1)(2)	F841BD123(1)300(2)
0.015	B04	5.5	10.5	18	15	8.7	100	PHE841EB5150(1)(2)	F841BD153(1)300(2)
0.018	B04	5.5	10.5	18	15	7.9	100	PHE841EB5180(1)(2)	F841BD183(1)300(2)
0.022	B05	5.5	12.5	18	15	7.2	100	PHE841EB5220(1)(2)	F841BE223(1)300(2)
0.027	B15	6	12	18	15	6.5	100	PHE841EB5270(1)(2)	F841BG273(1)300(2)
0.033	B10	6.5	12.5	18	15	5.9	100	PHE841EB5330(1)(2)	F841BE333(1)300(2)
0.039	B06	7.5	14.5	18	15	5.4	100	PHE841EB5390(1)(2)	F841BP393(1)300(2)
0.047	B06	7.5	14.5	18	15	5	100	PHE841EB5470(1)(2)	F841BP473(1)300(2)
0.056	B12	8	15	18	15	4.6	100	PHE841EB5560(1)(2)	F841BM563(1)300(2)
0.068	B11	8.5	16	18	15	4.2	100	PHE841EB5680(1)(2)	F841BS683(1)300(2)
0.082	B14	9.5	17.5	18	15	3.8	100	PHE841EB5820(1)(2)	F841BI823(1)300(2)
0.1	B14	9.5	17.5	18	15	3.7	100	PHE841EB6100(1)(2)	F841BI104(1)300(2)
0.068	D13	6.5	14.5	26	22.5	2.9	100	PHE841ED5680(1)(2)	F841DB683(1)300(2)
0.082	D17	7	16.5	26	22.5	2.8	100	PHE841ED5820(1)(2)	F841DF823(1)300(2)
0.1	D17	7	16.5	26	22.5	2.7	100	PHE841ED6100(1)(2)	F841DF104(1)300(2)
0.12	D14	8	16	26	22.5	2.6	100	PHE841ED6120(1)(2)	F841DH124(1)300(2)
0.15	D15	9	18.5	26	22.5	2.5	100	PHE841ED6150(1)(2)	F841DM154(1)300(2)
0.18	D18	10.5	19	26	22.5	2.3	100	PHE841ED6180(1)(2)	F841DR184(1)300(2)
0.22	D18	10.5	19	26	22.5	2.2	100	PHE841ED6220(1)(2)	F841DR224M300(2)
0.27	D16	11	21.5	26	22.5	2	100	PHE841ED6270M(2)	F841DT274(1)300(2)
0.33	D16	11	21.5	26	22.5	1.9	100	PHE841EY6330(1)(2)	F841YT334(1)300(2)
0.39	D19	15.5	24.5	26	22.5	1.6	100	PHE841ED6390(1)(2)	F841DY394(1)300(2)
0.47	D19	15.5	24.5	26	22.5	1.5	100	PHE841ED6470(1)(2)	F841DY474(1)300(2)
0.22	F11	10.5	20.5	31.5	27.5	2	100	PHE841EF6220(1)(2)	F841FE224(1)300(2)
0.27	F11	10.5	20.5	31.5	27.5	1.8	100	PHE841EF6270(1)(2)	F841FE274(1)300(2)
0.33	F12	11.5	22.5	31.5	27.5	1.6	100	PHE841EF6330(1)(2)	F841FG334(1)300(2)
0.39	F03	13.5	23	31.5	27.5	1.4	100	PHE841EF6390(1)(2)	F841FK394(1)300(2)
0.47	F03	13.5	23	31.5	27.5	1.3	100	PHE841EF6470(1)(2)	F841FK474(1)300(2)
0.56	F13	14.5	24.5	31.5	27.5	1.2	100	PHE841EF6560(1)(2)	F841FM564(1)300(2)
0.68	F14	17.5	28	31.5	27.5	1.1	100	PHE841EF6680(1)(2)	F841FN684(1)300(2)
0.82	F15	19	29	31.5	27.5	1	100	PHE841EF6820(1)(2)	F841FS824(1)300(2)
1	F16	21	30	31.5	27.5	1	100	PHE841EF7100(1)(2)	F841FV105(1)300(2)
0.68	R05	13	24	41	37.5	1.1	100	PHE841ER6680(1)(2)	F841RF684(1)300(2)
0.82	R04	15	26	41	37.5	1	100	PHE841ER6720(1)(2)	F841RH724(1)300(2)
1	R04	15	26	41	37.5	0.92	100	PHE841ER7100(1)(2)	F841RH105(1)300(2)
1.2	R02	16.5	32	41	37.5	0.84	100	PHE841ER7120(1)(2)	F841RD125(1)300(2)
1.5	R03	19	36	41	37.5	0.74	100	PHE841ER7150(1)(2)	F841RM155(1)300(2)
1.8	R06	21	38	41	37.5	0.67	100	PHE841ER7180(1)(2)	F841RP185(1)300(2)
2.2	R06	21	38	41	37.5	0.6	100	PHE841ER7220(1)(2)	F841RP225(1)300(2)
Capacitance Value (µF)	Box Code	T (mm)	H (mm)	L (mm)	Lead Spacing (S)	f _o (MHz)	dV/dt (V/µs)	KEMET Part Number	Legacy Part Number

(1) M = ±20%, K = ±10%.

(2) Insert lead and packaging code. See Ordering Options Table for available options.

Soldering Process

The implementation of the RoHS directive has resulted in the selection of SnAuCu (SAC) alloys or SnCu alloys as primary solder. This implementation has increased the liquidus temperature from 183°C for SnPb eutectic alloys to 217 – 221°C for the new alloys. As a result, the heat stress to the components, even in wave soldering, has increased considerably due to higher pre-heat and wave temperatures. Polypropylene capacitors are especially sensitive to heat (the melting point of polypropylene is 160 – 170°C). Wave soldering can be destructive, especially for mechanically small polypropylene capacitors (with lead spacing of 5 – 15 mm), and great care must be taken during soldering. The recommended solder profiles from KEMET should be used. Consult KEMET with any questions. In general, the wave soldering curve from IEC Publication 61760-1 Edition 2 serves as a solid guideline for successful soldering. See Figure 1.

Reflow soldering is not recommended for through-hole film capacitors. Exposing capacitors to a soldering profile in excess of the recommended limits may result in degradation of or permanent damage to the capacitors.

Do not place the polypropylene capacitor through an adhesive curing oven to cure resin for surface-mount components. Insert through-hole parts after curing the surface mount parts. Consult KEMET to discuss the actual temperature profile in the oven, if through-hole components must pass through the adhesive curing process. A maximum of two soldering cycles is recommended. Allow time for the capacitor surface temperature to return to normal before the second soldering cycle.

Manual Soldering Recommendations

Following is the recommendation for manual soldering with a soldering iron.

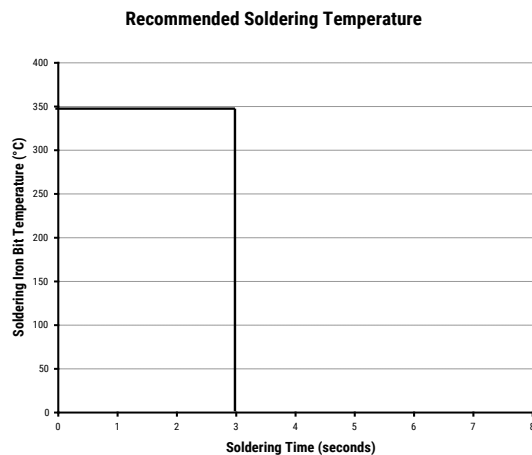

Soldering iron tip temperature should be set at 350°C (+10°C maximum), with the soldering duration not to exceed 3 seconds.

Wave Soldering Recommendations

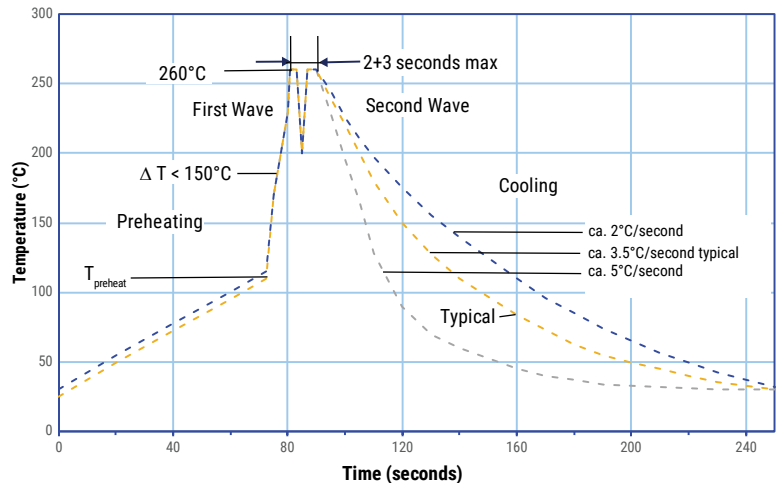

Soldering Process cont.

Wave Soldering Recommendations cont.

1. The table indicates the maximum set-up temperature of the soldering process.
Figure 1

Dielectric film material	Maximum Preheat Temperature		Maximum Peak Soldering Temperature	
	Capacitor Pitch \geq 10 mm	Capacitor Pitch $>$ 15 mm	Capacitor Pitch \leq 15 mm	Capacitor Pitch $>$ 15 mm
Polyester	130°C	130°C	270°C	270°C
Polypropylene	110°C	130°C	260°C	270°C
Paper	130°C	140°C	270°C	270°C
Polyphenylene Sulphide	150°C	160°C	270°C	270°C

2. The maximum temperature measured inside the capacitor: set the temperature so that the maximum temperature is below the limit inside the element.

Dielectric Film Material	Maximum Temperature Measured Inside the Element
Polyester	160°C
Polypropylene	110°C
Paper	160°C
Polyphenylene Sulphide	160°C

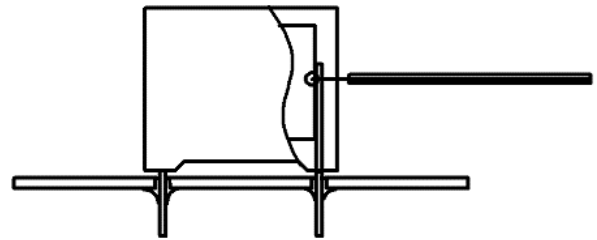

Temperature monitored inside the capacitor.

Selective Soldering Recommendations

Selective dip soldering is a variation of reflow soldering. In this method, the printed circuit board with through-hole components to be soldered is preheated and transported over the solder bath, as in normal flow soldering, without touching the solder. When the board is over the bath, it is stopped. Pre-designed solder pots are lifted from the bath with molten solder only at the places of the selected components, and then pressed against the lower surface of the board to solder the components.

The temperature profile for selective soldering is similar to the double-wave flow soldering outlined in this document. **However, instead of two baths, there is only one with a time from 3 to 10 seconds.** In selective soldering, the risk of overheating is greater than in double-wave flow soldering. Great care must be taken so that the parts do not overheat.

Metallized Polypropylene Film EMI Suppression Capacitors

PHE841, Class X1, 330 VAC, 100°C

Construction

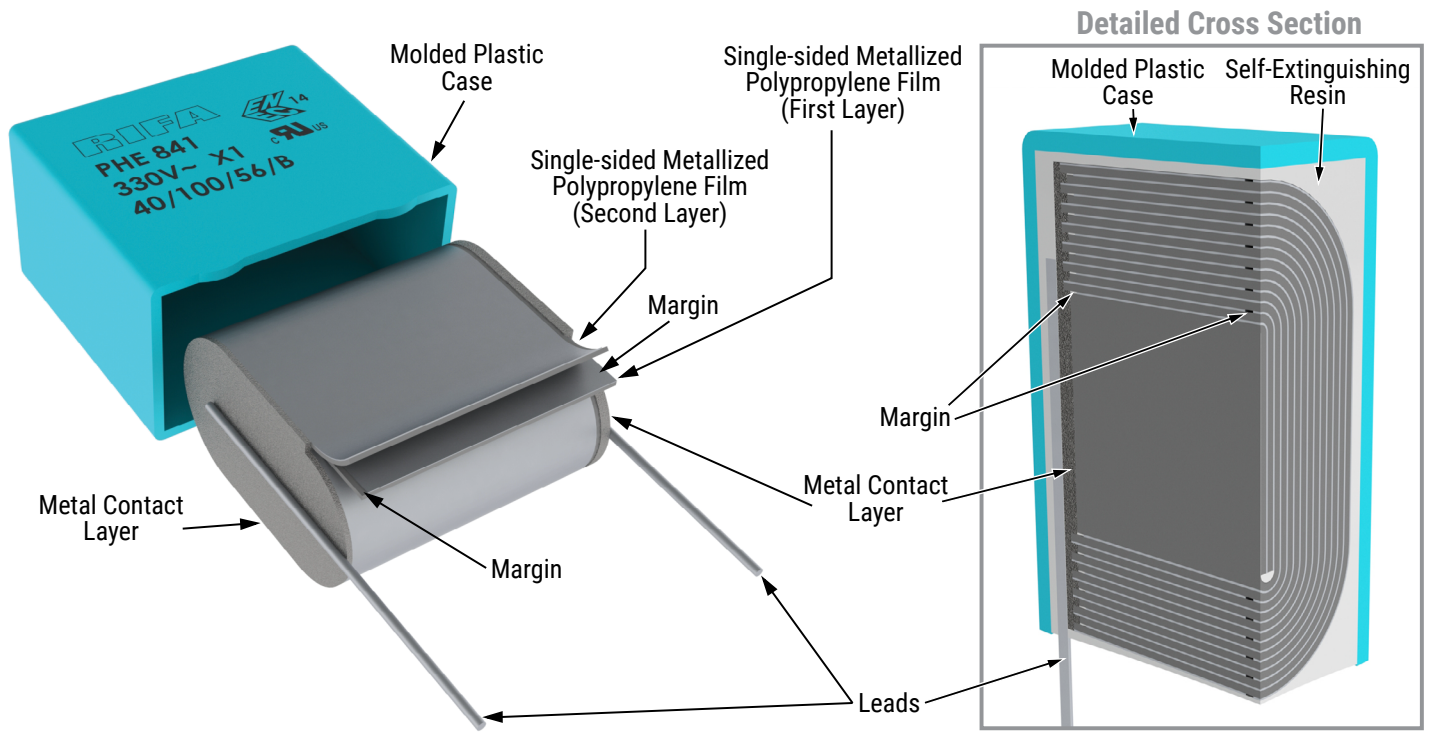

Winding Scheme

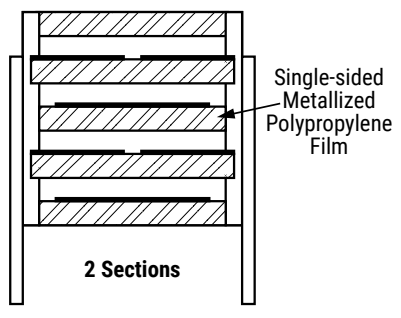

Metallized Polypropylene Film EMI Suppression Capacitors
PHE841, Class X1, 330 VAC, 100°C

Marking

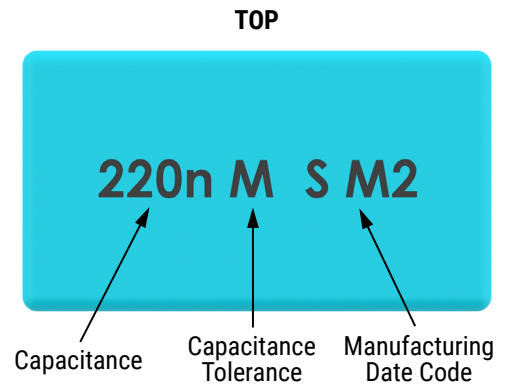
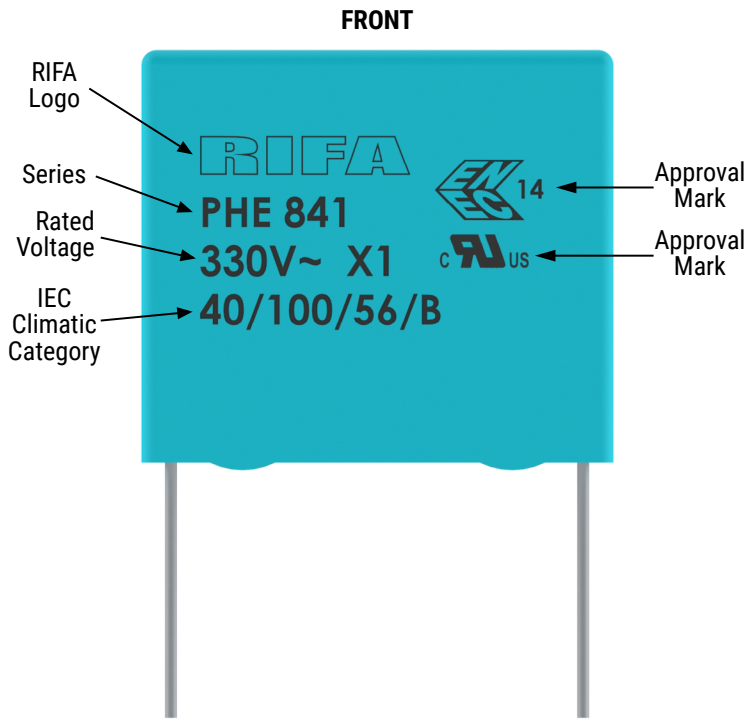

Manufacturing Date Code (IEC-60062)

Year	Code	Month	Code
2020	M	January	1
2021	N	February	2
2022	P	March	3
2023	R	April	4
2024	S	May	5
2025	T	June	6
2026	U	July	7
2027	V	August	8
2028	W	September	9
2029	X	October	0
2030	A	November	N
2031	B	December	D
2032	C		
2033	D		
2034	E		
2035	F		
2036	H		
2037	J		
2038	K		
2039	L		
2040	M		

Metallized Polypropylene Film EMI Suppression Capacitors

PHE841, Class X1, 330 VAC, 100°C

Packaging Quantities

Size Code	Lead Spacing	Thickness (mm)	Height (mm)	Length (mm)	Bulk Short Leads	Bulk Long Leads	Tray - Pizza Short Leads	Tray - Pizza Long Leads	Standard Reel ø 355 mm	Large Reel ø 500 mm	Ammo	Pizza
AH	10	4.5	10.5	13.0	2,000	2,200	-	-	750	1,500	1,000	-
AK		5.0	11.0	13.0	1,300	2,000	-	-	600	1,250	800	-
AP		6.0	12.0	13.0	1,000	1,800	-	-	500	1,000	680	-
BD	15	5.5	10.5	18.0	1,000	800	-	-	600	1,200	-	-
BE		5.5	12.5	18.0	800	1,000	-	-	550	1,100	750	1,020
BG		6.0	12.0	18.0	1,750	1,000	-	-	500	1,000	680	935
BJ		6.5	12.5	18.0	1,000	600	-	-	500	1000	-	-
BL		7.5	14.5	18.0	800	400	-	-	400	800	-	-
BM		8.0	15.0	18.0	600	400	-	-	400	800	-	-
BQ		8.5	16.0	18.0	600	400	-	-	400	800	-	-
BV		9.5	17.5	18.0	500	300	-	-	350	700	-	-
DD	22.5	6.5	14.5	26.0	234	-	-	-	300	600	-	440
DH		8.0	16.0	26.0	520	300	1026	513	240	500	330	492
DM		9.0	18.5	26.0	400	225	918	459	200	400	300	444
DT		11.0	21.5	26.0	253	-	-	-	200	400	-	253
DF		7.0	16.5	26.0	216	-	-	-	300	600	-	396
DR		10.5	19.0	26.0	264	-	-	-	200	400	-	264
DY		15.5	24.5	26.0	150	100	450	270	120	250	170	252
FK	27.5	13.5	23.0	31.5	171	-	-	-	-	250	-	171
FE		10.5	20.5	31.5	216	-	-	-	-	350	-	216
FG		11.5	22.5	31.5	198	-	-	-	-	300	-	198
FM		14.5	24.5	31.5	153	-	-	-	-	250	-	153
FR		17.5	28.0	31.5	126	-	-	-	-	-	-	126
FS		19.0	29.0	31.5	117	-	-	-	-	-	-	117
FV		21.0	30.0	31.5	108	-	-	-	-	-	-	108
RF	37.5	13.0	24.0	41.0	175	-	-	-	-	-	-	175
RH		15.0	26.0	41.0	119	-	-	-	-	-	-	119
RK		16.5	32.0	41.0	105	-	-	-	-	-	-	105
RM		19.0	36.0	41.0	91	-	-	-	-	-	-	91
RP		21.0	38.0	41.0	84	-	-	-	-	-	-	84

Lead Taping & Packaging (IEC 60286-2)

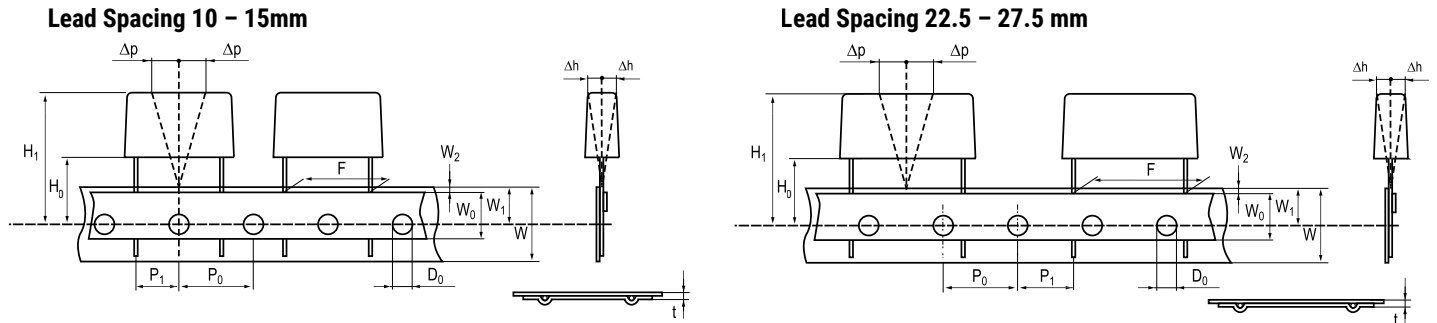

Taping Specification

Dimensions in mm							Standard IEC 60286-2
Lead Spacing	+0.6/-0.1	F	10	15	22.5	27.5	F
Carrier Tape Width	±0.5	W	18	18	18	18	18 ^{+1/-0.5}
Hold-Down Tape Width	Minimum	W ₀	5	5	5	5	
Position of Sprocket Hole	±0.5	W ₁	9	9	9	9	9 ^{+0.75/-0.5}
Distance Between Tapes	Maximum	W ₂	3	3	3	3	3.0
Sprocket Hole Diameter	±0.2	D ₀	4	4	4	4	4.0
Feed Hole Lead Spacing	±0.3	P ₀ ⁽¹⁾	12.7	12.7	12.7	12.7	12.7
Distance Lead – Feed Hole	±0.7	P ₁	7.7	5.2	5.3	5.3	P ¹
Deviation Tape – Plane	Maximum	Δp	1.3	1.3	1.3	1.3	1.3
Lateral Deviation	Maximum	Δh	2	2	2	2	2.0
Total Thickness	±0.2	t	0.7	0.7	0.9 ^{MAX}	0.9 ^{MAX}	0.9 ^{MAX}
Sprocket Hole/Cap Body	Nominal	H ₀ ⁽²⁾	18.5±0.5	18.5±0.5	18.5±0.5	18.5±0.5	18.0 ^{+2/-0}
Sprocket Hole/Top of Cap Body	Maximum	H ₁ ⁽³⁾	43	43	58	58	58 ^{MAX}

(1) Maximum cumulative feed hole error, 1 mm per 20 parts.

(2) 16.5 mm available on request.

(3) Depending on case size.

KEMET Electronics Corporation Sales Offices

For a complete list of our global sales offices, please visit <https://www.yageogroup.com/SalesResources/SalesOffices>

Disclaimer

YAGEO Corporation and its affiliates do not recommend the use of commercial or automotive grade products for high reliability applications or manned space flight.

All product specifications, statements, information and data (collectively, the "Information") in this datasheet are subject to change. The customer is responsible for checking and verifying the extent to which the Information contained in this publication is applicable to an order at the time the order is placed. All Information given herein is believed to be accurate and reliable, but it is presented without guarantee, warranty, or responsibility of any kind, expressed or implied.

Statements of suitability for certain applications are based on KEMET Electronics Corporation's ("KEMET") knowledge of typical operating conditions for such applications, but are not intended to constitute – and KEMET specifically disclaims – any warranty concerning suitability for a specific customer application or use. The Information is intended for use only by customers who have the requisite experience and capability to determine the correct products for their application. Any technical advice inferred from this Information or otherwise provided by KEMET with reference to the use of KEMET's products is given gratis, and KEMET assumes no obligation or liability for the advice given or results obtained.

Although KEMET designs and manufactures its products to the most stringent quality and safety standards, given the current state of the art, isolated component failures may still occur. Accordingly, customer applications which require a high degree of reliability or safety should employ suitable designs or other safeguards (such as installation of protective circuitry or redundancies) in order to ensure that the failure of an electrical component does not result in a risk of personal injury or property damage.

Although all product-related warnings, cautions and notes must be observed, the customer should not assume that all safety measures are indicated or that other measures may not be required.

Additional information about production site flexibility can be found [<here>](#)

KEMET is a registered trademark of KEMET Electronics Corporation.