

NOT FOR NEW DESIGN

Overview

Multilayer metallized paper encapsulated and impregnated in self-extinguishing material that meets the requirements of UL 94 V-0.

Applications

For worldwide use in contact protection, contact interference suppression, and transient suppression.

Benefits

- Approvals: ENEC, UL, cUL
- Rated voltage: 250 VAC 50/60 Hz
- Capacitance range: 0.022 – 0.1 μ F
- Capacitance tolerance: \pm 20%
- Resistance range: 100 Ω
- Resistance tolerance: \pm 30%
- Lead Spacing: 15.2 – 25.4 mm
- Climatic category: 40/085/56/B, IEC 60068-1
- Tape and reel packaging in accordance with IEC 60286-2
- RoHS compliance and lead-free terminations
- Operating temperature range of -40°C to +85°C

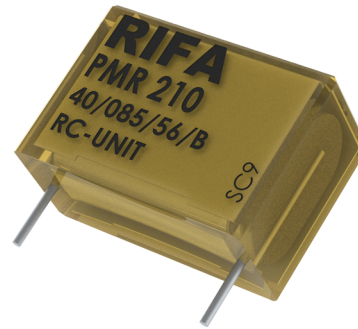

Legacy Part Number System

PMR210	M	B	5220	M	100	R30
Series	Rated Voltage (VAC)	Lead Spacing (mm)	Capacitance Code (pF)	Capacitance Tolerance	Resistance (Ω)	Packaging
RC Snubber, Metallized Paper	M = 250	B = 15.2 C = 20.3 E = 25.4	The last three digits represent significant figures. The first digit specifies the total number of digits.	M = \pm 20%	Resistance value in Ω	See Ordering Options Table

New KEMET Part Number System

P	410	Q	M	223	M	250	A	H101
Capacitor Class	Series	Lead Spacing (mm)	Size Code	Capacitance Code (pF)	Capacitance Tolerance	Rated Voltage (VAC)	Lead and Packaging Code	Resistance (Ω)
P = Metallized Paper	RC Snubber	Q = 15.2 C = 20.3 E = 25.4	See Dimension Table	First two digits represent significant figures. Third digit specifies number of zeros.	M = \pm 20%	250 = 250	See Ordering Options Table	H plus first two digits represent significant figures. Third digit specifies number of zeros.

Benefits cont.

NOT FOR NEW DESIGN

- Excellent self-healing properties that ensure long life, even when subjected to frequent over-voltages
- Good resistance to ionization due to impregnated paper dielectric
- High dv/dt capability
- Impregnated paper that ensures excellent stability and reliability properties, particularly in applications with continuous operation

Ordering Options Table

Lead Spacing Nominal (mm)	Type of Leads and Packaging	Lead Length (mm)	KEMET Lead and Packaging Code	Legacy Lead and Packaging Code
15.2	Standard Lead and Packaging Options			
	Bulk (Bag) – Short Leads	6 +0/-1	C	R06
	Bulk (Bag) – Maximum Length Leads	30 +5/-0	A	R30
	Tape & Reel (Standard Reel Φ = 360 mm)	$H_0 = 18.5 \pm 0.5$	L	R19T0
20.3	Standard Lead and Packaging Options			
	Bulk (Tray) – Short Leads	6 +0/-1	C	R06
	Bulk (Bag) – Maximum Length Leads	30 +5/-0	A	R30
	Tape & Reel (Standard Reel Φ = 360 mm)	$H_0 = 18.5 \pm 0.5$	L	R19T0
25.4	Standard Lead and Packaging Options			
	Bulk (Bag) – Short Leads	6 +0/-1	C	R06
	Bulk (Tray) – Maximum Length Leads	30 +5/-0	A	R30

Dimensions – Millimeters

NOT FOR NEW DESIGN

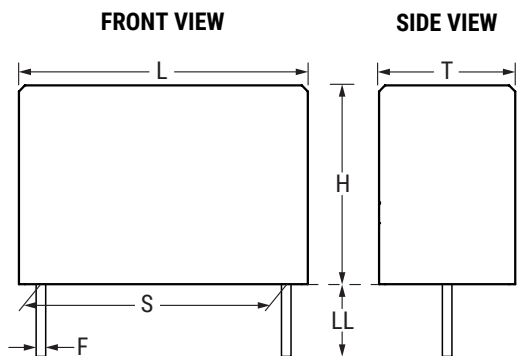

Size Code	S		T		H		L		F	
	Nominal	Tolerance	Nominal	Tolerance	Nominal	Tolerance	Nominal	Tolerance	Nominal	Tolerance
QM	15.2	±0.4	7.3	Maximum	13.0	Maximum	18.5	Maximum	0.8	±0.05
QS	15.2	±0.4	8.5	Maximum	14.3	Maximum	18.5	Maximum	0.8	±0.05
CJ	20.3	±0.4	9.0	Maximum	15.0	Maximum	24.0	Maximum	0.8	±0.05
CP	20.3	±0.4	11.3	Maximum	16.5	Maximum	24.0	Maximum	0.8	±0.05
EE	25.4	±0.4	10.6	Maximum	16.1	Maximum	30.5	Maximum	1.0	±0.05

Note: See the Ordering Options Table for lead length (LL) options.

Performance Characteristics

NOT FOR NEW DESIGN



Rated Voltage	250 VAC 50/60 Hz												
Capacitance Range	0.022 – 0.1 μ F												
Capacitance Tolerance	\pm 20%												
Resistance Range	100 Ω												
Resistance Tolerance	\pm 30%												
Temperature Range	-40°C to +85°C												
Climatic Category	40/085/56/B												
Approvals	ENEC, UL, cUL												
Peak Pulse Voltage	1,000 V												
Series Resistance	The series resistance is defined at 1 kHz for RC \geq 50 μ s and at 100 kHz for RC < 50 μ s												
Insulation Resistance	Minimum Value Between Terminals												
	\geq 1,000 M Ω												
Pulse Current	Maximum 12 A repetitive. Maximum 20 A peak for occasional transients.												
Test Voltage Between Terminals	The 100% screening factory test is carried out at 3,000 VDC. The voltage level is selected to meet the requirements in applicable equipment standards. All electrical characteristics are checked after the test.												
In DC Applications	Recommended voltage \leq 1,000 VDC												
Power Ratings	Average losses may reach 0.5 W, provided the surface temperature does not exceed +85°C. For maximum permitted power dissipation versus temperature, see Derating Curves.												
Derating Curves	Maximum Allowable Power Dissipation vs. Ambient Temperature and Case Sizes.												
	<table border="1"> <thead> <tr> <th>Curve</th> <th>Dimension B (mm)</th> </tr> </thead> <tbody> <tr> <td>1</td> <td>7.3</td> </tr> <tr> <td>1</td> <td>8.5</td> </tr> <tr> <td>2</td> <td>9.0</td> </tr> <tr> <td>3</td> <td>11.3</td> </tr> <tr> <td>4</td> <td>10.6</td> </tr> </tbody> </table>	Curve	Dimension B (mm)	1	7.3	1	8.5	2	9.0	3	11.3	4	10.6
	Curve	Dimension B (mm)											
	1	7.3											
	1	8.5											
2	9.0												
3	11.3												
4	10.6												

Environmental Test Data

NOT FOR NEW DESIGN

Test	IEC Publication	Procedure
Endurance	IEC 60384-14	1.25 x V _R VAC 50 Hz, once every hour increased to 1,000 VAC for 0.1 second, 1,000 hours at upper rated temperature.
Vibration	IEC 60068-2-6 Test Fc	3 directions at 2 hours each, 10 – 500 Hz at 0.75 mm or 98 m/s ²
Bump	IEC 60068-2-29 Test Eb	4,000 bumps at 390 m/s ²
Change of Temperature	IEC 60068-2-14 Test Na	Upper and lower rated temperature, 5 cycles
Active Flammability	IEC 60384-14	V _R +20 surge pulses at 4.0 kV (pulse every 5 seconds)
Passive Flammability	IEC 60384-14	IEC 60384-1, IEC 60695-11-5 Needle-flame test
Damp Heat Steady State	IEC 60068-2-78 Test Cab	+40°C and 93% RH, 56 days

Approvals

Certification Body	Mark	Specification	File Number
Intertek Semko AB		EN/IEC 60384-14	SE/0140-36A *
UL		UL 60384-14 and CAN/CSA-E60384-14-09	E97797

* Products manufactured after 1st March 2026 are not covered by the ENEC certification mark, in accordance with PCN-121525-KB

Environmental Compliance

All KEMET EMI capacitors are RoHS Compliant.



Table 1 – Ratings & Part Number Reference

Lead Spacing (p)	Capacitance Value (µF)	Resistance (Ω)	Maximum Dimensions in mm			New KEMET Part Number	Legacy Part Number
			B	H	L		
15.2	0.022	100	7.3	13.0	18.5	P410QM223M250(1)H101	PMR210MB5220M100(1)
15.2	0.033	100	8.5	14.3	18.5	P410QS333M250(1)H101	PMR210MB5330M100(1)
20.3	0.047	100	9.0	15.0	24.0	P410CJ473M250(1)H101	PMR210MC5470M100(1)
20.3	0.068	100	11.3	16.5	24.0	P410CP683M250(1)H101	PMR210MC5680M100(1)
25.4	0.1	100	10.6	16.1	30.5	P410EE104M250(1)H101	PMR210ME6100M100(1)

(1) Insert lead and packaging code. See Ordering Options Table for available options.

Soldering Process **NOT FOR NEW DESIGN**

The implementation of the RoHS directive has resulted in the selection of SnAuCu (SAC) alloys or SnCu alloys as primary solder. This has increased the liquidus temperature from that of 183°C for SnPb eutectic alloy to 217 – 221°C for the new alloys. As a result, the heat stress to the components, even in wave soldering, has increased considerably due to higher pre-heat and wave temperatures. Polypropylene capacitors are especially sensitive to heat (the melting point of polypropylene is 160 – 170°C). Wave soldering can be destructive, especially for mechanically small polypropylene capacitors (with lead spacing of 5 – 15 mm), and great care must be taken during soldering. The recommended solder profiles from KEMET should be used. Consult KEMET with any questions. In general, the wave soldering curve from IEC Publication 61760-1 Edition 2 serves as a solid guideline for successful soldering. See Figure 1.

Reflow soldering is not recommended for through-hole film capacitors. Exposing capacitors to a soldering profile in excess of the recommended limits may result in degradation of or permanent damage to the capacitors.

Do not place the polypropylene capacitor through an adhesive curing oven to cure resin for surface-mount components. Insert through-hole parts after curing the surface-mount parts. Consult KEMET to discuss the actual temperature profile in the oven, if through-hole components must pass through the adhesive curing process. A maximum of two soldering cycles is recommended. Allow time for the capacitor surface temperature to return to a normal temperature before the second soldering cycle.

Manual Soldering Recommendations

Following is the recommendation for manual soldering with a soldering iron.

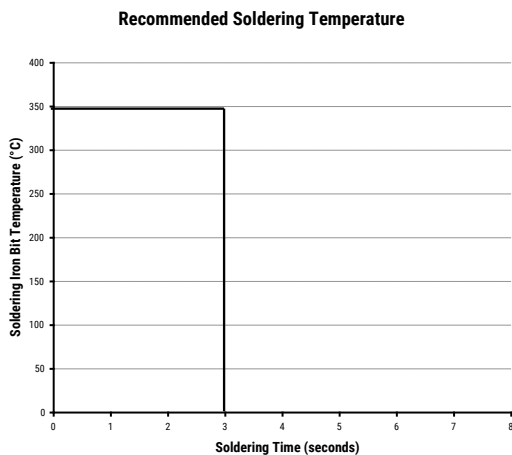

Soldering iron tip temperature should be set at 350°C (+10°C maximum), with the soldering duration not to exceed more than 3 seconds.

Wave Soldering Recommendations

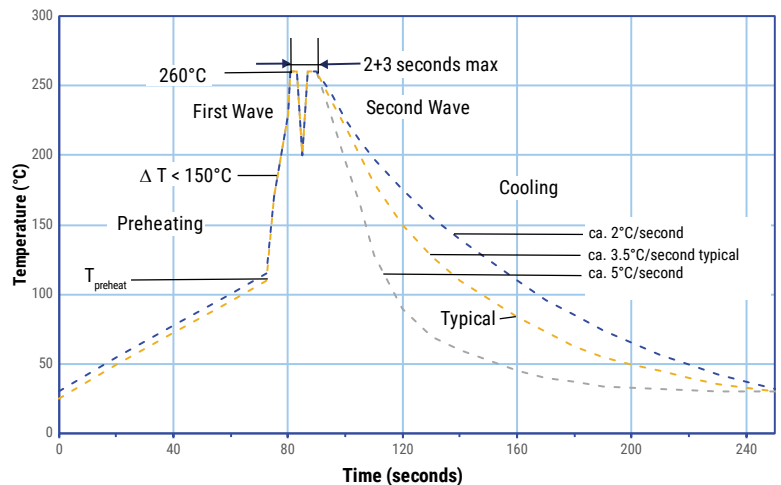

Soldering Process cont.

NOT FOR NEW DESIGN

Wave Soldering Recommendations cont'd

1. The table indicates the maximum setup temperature for the soldering process.

Dielectric film material	Maximum Preheat Temperature			Maximum Peak Soldering Temperature	
	Capacitor Pitch ≤ 10 mm	Capacitor Pitch = 15 mm	Capacitor Pitch > 15 mm	Capacitor Pitch ≤ 15 mm	Capacitor Pitch > 15 mm
Polyester	130°C	130°C	130°C	270°C	270°C
Polypropylene	100°C	110°C	130°C	260°C	270°C
Paper	130°C	130°C	140°C	270°C	270°C
Polyphenylene Sulphide	150°C	150°C	160°C	270°C	270°C

2. The maximum temperature measured inside the capacitor: set the temperature so that inside the element the maximum temperature is below the limit.

Dielectric Film Material	Maximum Temperature Measured Inside the Element
Polyester	160°C
Polypropylene	110°C
Paper	160°C
Polyphenylene Sulphide	160°C

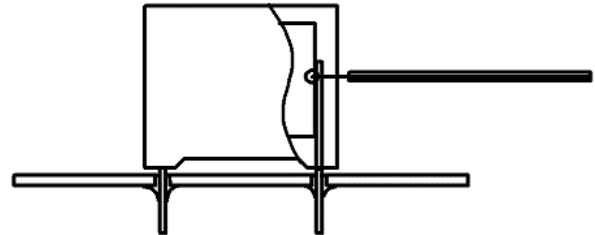

Temperature monitored inside the capacitor.

Selective Soldering Recommendations

Selective dip soldering is a variation of reflow soldering. In this method, the printed circuit board with through-hole components to be soldered is preheated and transported over the solder bath, as in normal flow soldering, without touching the solder. When the board is over the bath, it is stopped. Pre-designed solder pots are lifted from the bath with molten solder, only at the places of the selected components, and pressed against the lower surface of the board to solder the components.

The temperature profile for selective soldering is similar to the double wave flow soldering outlined in this document. **However, instead of two baths, there is only one with a time from 3 to 10 seconds.** In selective soldering, the risk of overheating is greater than in double wave flow soldering. Great care must be taken so that the parts do not overheat.

Construction

NOT FOR NEW DESIGN

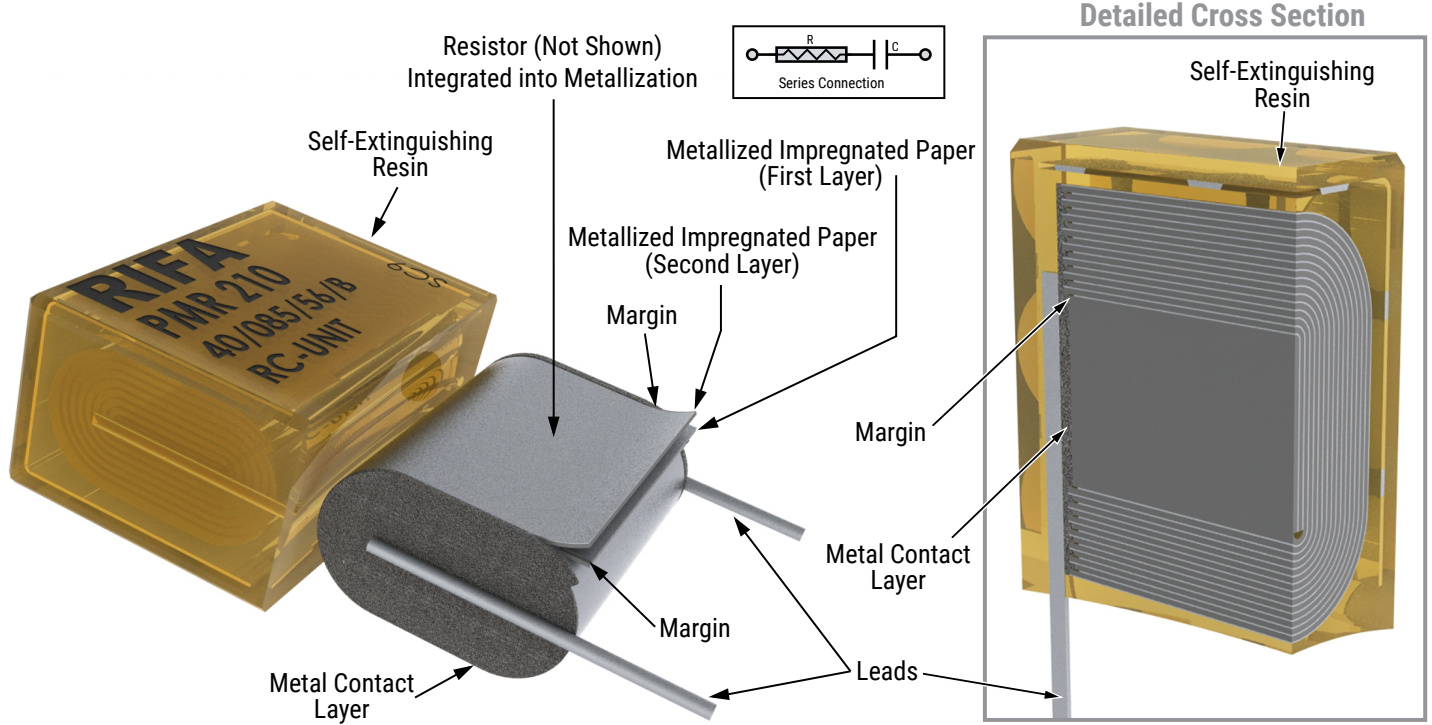

Winding Scheme

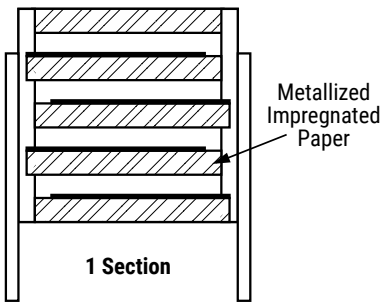

Marking

NOT FOR NEW DESIGN

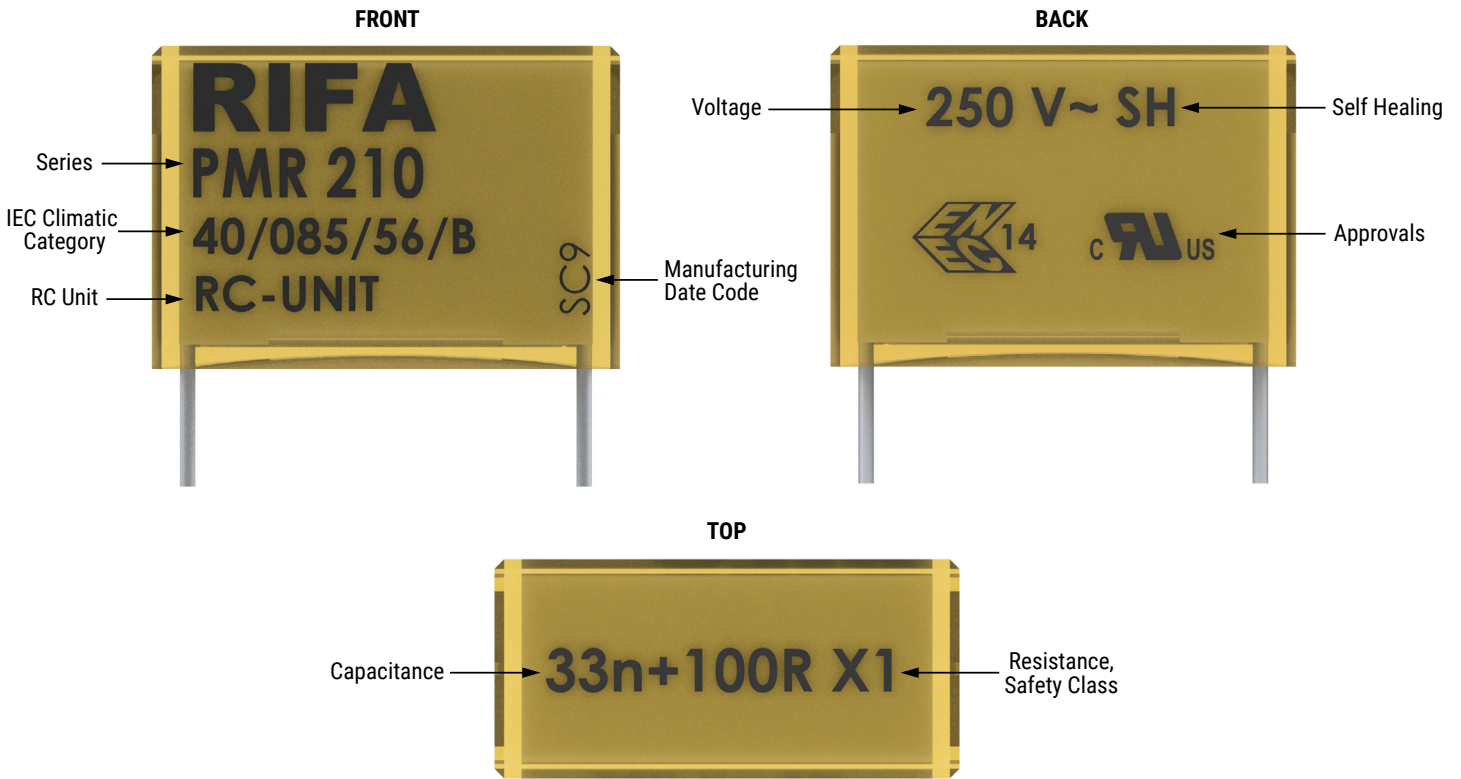

Packaging Quantities

Size Code	Lead Spacing (mm)	Thickness (mm)	Height (mm)	Length (mm)	Bulk Short Leads	Bulk Long Leads	Standard Reel 360 mm
Lead and Packaging Code					C/R06	A/R30	L/R19T0
QM	15.2	7.3	13.0	18.5	600	400	400
QS	15.2	8.5	14.3	18.5	500	300	350
CJ	20.3	9.0	15.0	24.0	1,530	200	250
CP	20.3	11.3	16.5	24.0	1,080	150	180
EE	25.4	10.6	16.1	30.5	1,008	150	

Lead Taping & Packaging (IEC 60286-2)

NOT FOR NEW DESIGN

Lead Spacing 10.2 – 15.2 mm

Lead Spacing 20.3 – 22.5 mm

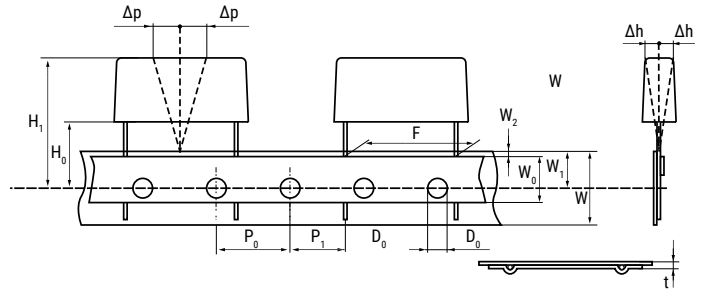
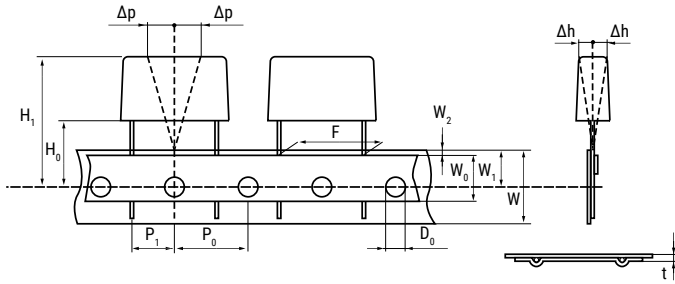

Formed Leads from 10.2 – 7.5 mm

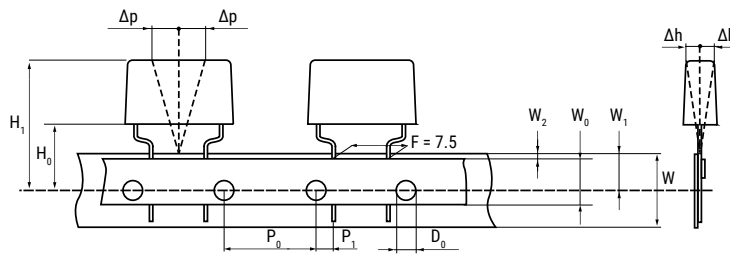

Taping Specification

Dimensions in mm								Standard IEC 60286-2
Lead Spacing	+0.6/-0.1	F	Formed 7.5	10.2	15.2	20.3	22.5	F
Carrier Tape Width	±0.5	W	18.0	18.0	18.0	18.0	18.0	18 +1/-0.5
Hold-Down Tape Width	Minimum	W ₀	5.0	5.0	5.0	5.0	5.0	
Position of Sprocket Hole	±0.5	W ₁	9.0	9.0	9.0	9.0	9.0	9 +0.75/-0.5
Distance Between Tapes	Maximum	W ₂	3.0	3.0	3.0	3.0	3.0	3.0
Sprocket Hole Diameter	±0.2	D ₀	4.0	4.0	4.0	4.0	4.0	4.0
Feed Hole Lead Spacing	±0.3	P ₀ ⁽¹⁾	12.7 ⁽⁴⁾	12.7	12.7	12.7	12.7	12.7
Distance Lead – Feed Hole	±0.7	P ₁	3.75	7.6	5.1	8.9	5.3	P ¹
Deviation Tape – Plane	Maximum	Δp	1.3	1.3	1.3	1.3	1.3	1.3
Lateral Deviation	Maximum	Δh	2.0	2.0	2.0	2.0	2.0	2.0
Total Thickness	±0.2	t	0.7	0.7	0.7	0.7	0.9 Maximum	0.9 Maximum
Sprocket Hole/Cap Body	Nominal	H ₀ ⁽²⁾	18 +2/-0	18 +2/-0	18 +2/-0	18 +2/-0	18.5 ±0.5	18 +2/-0
Sprocket Hole/Top of Cap Body	Maximum	H ₁ ⁽³⁾	43	43	43	58	58	58 Maximum

(1) Maximum cumulative feed hole error, 1 mm per 20 parts

(2) 16.5 mm available on request

(3) Depending on case size

(4) 15 mm available on request

NOT FOR NEW DESIGN

Lead Taping & Packaging (IEC 60286-2) cont.

Ammo Specifications

Series	Dimensions (mm)		
	H	W	T
R4x, R4x+R, R7x, RSB	360	340	59
F5A, F5B, F5D			
F6xx, F8xx			
PHExxx, PMExxx, PMRxxx	330	330	50

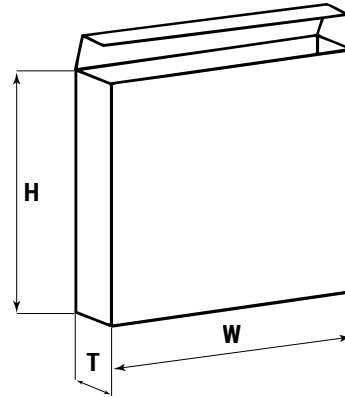

Reel Specifications

Series	Dimensions (mm)		
	D	H	W
R4x, R4x+R, R7x, RSB	355 500	30	55 (Max)
F5A, F5B, F5D		25	
F6xx, F8xx			
PHExxx, PMExxx, PMRxxx	360 500	30	46 (Max)

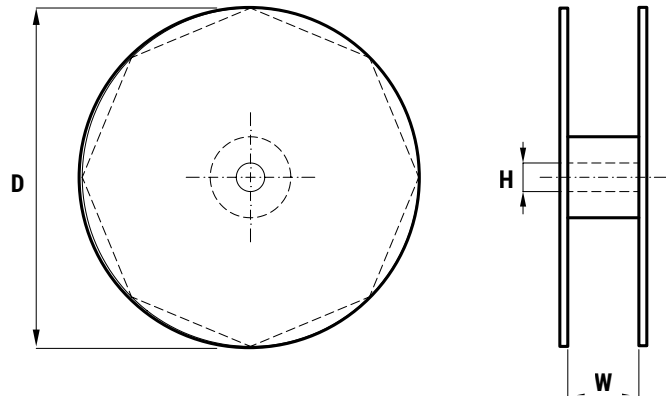

KEMET Electronics Corporation Sales Offices

NOT FOR NEW DESIGN

For a complete list of our global sales offices, please visit <https://www.yageogroup.com/SalesResources/SalesOffices>

Disclaimer

YAGEO Corporation and its affiliates do not recommend the use of commercial or automotive grade products for high reliability applications or manned space flight.

All product specifications, statements, information and data (collectively, the "Information") in this datasheet are subject to change. The customer is responsible for checking and verifying the extent to which the Information contained in this publication is applicable to an order at the time the order is placed. All Information given herein is believed to be accurate and reliable, but it is presented without guarantee, warranty, or responsibility of any kind, expressed or implied.

Statements of suitability for certain applications are based on KEMET Electronics Corporation's ("KEMET") knowledge of typical operating conditions for such applications, but are not intended to constitute – and KEMET specifically disclaims – any warranty concerning suitability for a specific customer application or use. The Information is intended for use only by customers who have the requisite experience and capability to determine the correct products for their application. Any technical advice inferred from this Information or otherwise provided by KEMET with reference to the use of KEMET's products is given gratis, and KEMET assumes no obligation or liability for the advice given or results obtained.

Although KEMET designs and manufactures its products to the most stringent quality and safety standards, given the current state of the art, isolated component failures may still occur. Accordingly, customer applications which require a high degree of reliability or safety should employ suitable designs or other safeguards (such as installation of protective circuitry or redundancies) in order to ensure that the failure of an electrical component does not result in a risk of personal injury or property damage.

Although all product-related warnings, cautions and notes must be observed, the customer should not assume that all safety measures are indicated or that other measures may not be required.

Additional information about production site flexibility can be found [<here>](#)

KEMET is a registered trademark of KEMET Electronics Corporation.