

RF Inductor



BWHP Series



Overview

Wire-wound RF inductors are electronic components designed to store energy in a magnetic field when electrical current passes through them. They are constructed by winding a conductive wire (usually copper or gold-plated) around a core material such as air, ceramic, or ferrite.

This configuration allows them to provide high inductance values with minimal power loss, especially at high frequencies.

Benefits

1. High Q-Factor (Quality Factor)
2. Ceramic body and wire wound construction provide high SRFs
3. Low DC resistance design
4. High Current Handling
5. Can maintain excellent thermal stability at different temperatures

Applications

1. Industrial and Medical Equipmen: RFID systems and medical imaging equipment.
2. Data Centers
3. Networking
4. Base Station
5. Consumer Electronics
6. Security system

Product Information

Series	Size Code (JIS/EIA)	Inductance (nH)
BWHP	1005/0402 1608/0603 2012/0805	1 ~ 820



BWHP00110706 Series Specification

1 Scope: This specification applies to Wire Wound Ceramic Chip Inductors

2 Part Numbering:

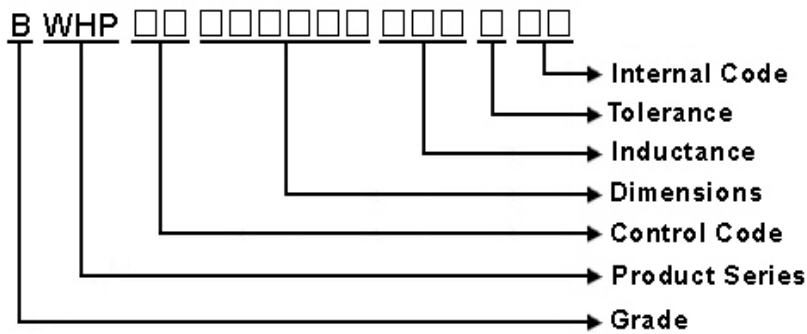

3 Rating:

Operating Temperature: - 40°C ~ 125°C
(Including self - temperature rise)

Storage Temperature: - 40°C ~ 125°C
(The storage temperature range is for after the assembly)

4 Marking:

No Marking

5 Standard Testing Condition

	Unless otherwise specified	In case of doubt
Temperature	Ordinary Temperature(15 to 35°C)	20 to 30°C
Humidity	Ordinary Humidity(25 to 85% RH)	50 to 80 %RH

BWHP00110706 Series Specification

6 Configuration and Dimensions and Unit Weight:

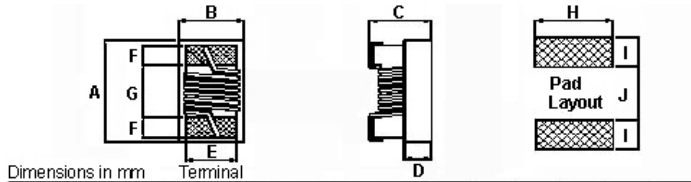

Dimensions in mm

TYPE	A	B	C	D	E	F	G	H	I	J
110706	1.1±0.05	0.7±0.05	0.6±0.05	0.25ref	0.45	0.2	0.54	0.66	0.36	0.51

Net Weight (grms)

SIZE CODE	Net Weight (grms)
110706	0.0008 (typ.)

7 Electrical Characteristics:

Part No.	Inductance (nH)	L/Q Test Freq. (MHz)	Q Typ.	SRF (MHz)Typ.	RDC (Ω)Max.	I _{rms} (mA)Max.	Tolerance (±%)
BWHP001107061N0□00	1	250/250	18	16000	0.03	2300	0.1nH,2
BWHP001107062N0□00	2	250/250	18	15200	0.038	2100	0.2nH,2
BWHP001107062N2□00	2.2	250/250	25	15100	0.045	2100	0.2nH,2
BWHP001107062N4□00	2.4	250/250	25	14000	0.045	2000	0.2nH,2
BWHP001107062N7□00	2.7	250/250	20	13000	0.09	1500	0.2nH,2
BWHP001107063N3□00	3.3	250/250	20	12800	0.05	1700	2,3,5
BWHP001107063N6□00	3.6	250/250	28	11700	0.065	1700	2,3,5
BWHP001107063N9□00	3.9	250/250	28	9500	0.065	1700	2,3,5
BWHP001107064N3□00	4.3	250/250	22	7150	0.06	1600	2,3,5
BWHP001107064N7□00	4.7	250/250	18	6850	0.115	1500	2,3,5
BWHP001107065N1□00	5.1	250/250	20	6800	0.125	1200	2,3,5
BWHP001107065N6□00	5.6	250/250	28	6800	0.07	1600	2,3,5
BWHP001107066N2□00	6.2	250/250	25	5800	0.07	1600	2,3,5
BWHP001107066N8□00	6.8	250/250	25	5800	0.095	1500	2,3,5
BWHP001107067N5□00	7.5	250/250	25	5400	0.13	1400	2,3,5
BWHP001107068N2□00	8.2	250/250	30	5400	0.08	1500	2,3,5
BWHP001107068N7□00	8.7	250/250	30	5000	0.085	1500	2,3,5
BWHP001107069N0□00	9	250/250	28	5000	0.09	1400	2,3,5
BWHP001107069N5□00	9.5	250/250	30	4700	0.095	1400	2,3,5
BWHP0011070610N□00	10	250/250	30	4700	0.12	1300	2,3,5
BWHP0011070611N□00	11	250/250	30	4700	0.095	1400	2,3,5
BWHP0011070612N□00	12	250/250	25	4400	0.11	1200	2,3,5
BWHP0011070613N□00	13	250/250	30	4200	0.14	870	2,3,5
BWHP0011070615N□00	15	250/250	30	3900	0.13	1100	2,3,5
BWHP0011070616N□00	16	250/250	30	3700	0.15	850	2,3,5

NOTE: □-tolerance B=±0.1nH / C=±0.2nH / H=±3% / J=±5%

1. Operating temperature range - 4 0 °C ~ 1 2 5 °C (Including self - temperature rise)
2. I_{rms} for a 15°C temperature rise from 25°C ambient.
3. L/Q Test OSC @200mV.
4. Inductance would be correct Chilisin standard piece.
5. weight: 0.8(mg) typ.

BWHP00110706 Series Specification

Part No.	Inductance (nH)	L/Q Test Freq. (MHz)	Q Typ.	SRF (MHz)Typ.	RDC (Ω)Max.	I _{rms} (mA)Max.	Tolerance (\pm %)
BWHP0011070618N□00	18	250/250	30	3550	0.16	900	2,3,5
BWHP0011070619N□00	19	250/250	30	3500	0.175	850	2,3,5
BWHP0011070620N□00	20	250/250	30	3500	0.22	780	2,3,5
BWHP0011070621N□00	21	250/250	30	1700	0.36	450	2,3,5
BWHP0011070622N□00	22	250/250	30	3300	0.21	800	2,3,5
BWHP0011070623N□00	23	250/250	30	3150	0.21	700	2,3,5
BWHP0011070624N□00	24	250/250	30	3150	0.26	700	2,3,5
BWHP0011070625N□00	25	250/250	30	3150	0.31	700	2,3,5
BWHP0011070626N□00	26	250/250	30	3150	0.275	700	2,3,5
BWHP0011070627N□00	27	250/250	30	3200	0.3	450	2,3,5
BWHP0011070630N□00	30	250/250	30	2900	0.35	450	2,3,5
BWHP0011070633N□00	33	250/250	30	2800	0.38	490	2,3,5
BWHP0011070636N□00	36	250/250	30	2800	0.48	480	2,3,5
BWHP0011070637N□00	37	250/250	30	2700	0.49	470	2,3,5
BWHP0011070639N□00	39	250/250	30	2600	0.52	450	2,3,5
BWHP0011070640N□00	40	250/250	30	2600	0.52	450	2,3,5
BWHP0011070643N□00	43	250/250	29	2500	0.72	450	2,3,5
BWHP0011070647N□00	47	250/250	30	2400	0.72	420	2,3,5
BWHP0011070651N□00	51	250/250	30	2300	0.98	360	2,3,5

NOTE: □-tolerance B=±0.1nH / C=±0.2nH / H=±3% / J=±5%

1. Operating temperature range - 4 0 °C ~ 1 2 5 °C (Including self - temperature rise)
2. I_{rms} for a 15°C temperature rise from 25°C ambient.
3. L/Q Test OSC @200mV.
4. Inductance would be correct Chilisin standard piece.
5. weight: 0.8(mg) typ.

BWHP00110706 Series Specification

8 BWHP00110706 Series
8.1 Construction:

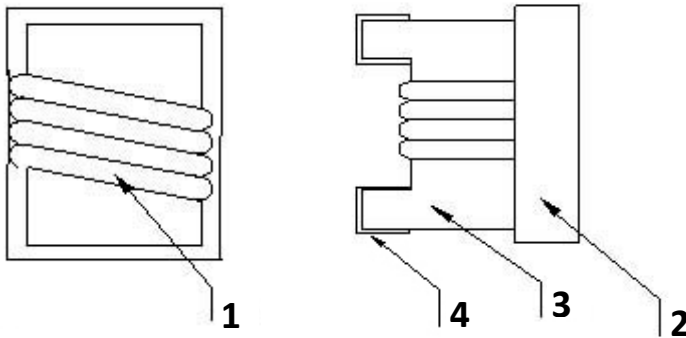

8.2 Material List:

16	PART	MATERIAL
1	WIRE	COPPER 180
2	EPOXY	UV GLUE
3	CORE	CERAMIC
4	TERMINAL	Ag/Ni/Sn

BWHP00110706 Series Specification

9 Reliability Of Ceramic Wire Wound Chip Inductor/CERAMIC SERIES

1-1.Environmental Performance

No	Item	Specification	Test Method		
1-1-1	Temperature Cycle	Appearance: No Damage Inductance: within $\pm 10\%$ of initial value Q change: within $\pm 30\%$ of initial value	One cycle:		
			Step	Temperature ($^{\circ}\text{C}$)	Time (min)
			1	-40 \pm 3	30
			2	25 \pm 2	15
			3	125 \pm 3	30
4	25 \pm 2	15			
1-1-2	High Temperature Resistance	There should be no evidence of short or open circle	Total: 5 cycles Measured After Exposure in The Room Condition For 1hrs Temperature: 125 \pm 3 $^{\circ}\text{C}$ Time: 1000Hrs Measured After Exposure In The Room Condition For 1Hrs		
1-1-3	Low Temperature Resistance		Temperature: -40 \pm 3 $^{\circ}\text{C}$ Time: 1000Hrs Measured After Exposure In The Room Condition For 1Hrs		
1-1-4	Humidity Load Life		Temperature: 40 \pm 2 $^{\circ}\text{C}$ Relative Humidity: 90~95% Load: Allowed DC Current Time: 96Hrs		

1-2.Mechanical Performance

No	Item	Specification	Test Method
1-2-1	Vibration Test (Low Frequency)	1.Appearance: No Damage 2.Inductance: within $\pm 10\%$ of initial value 3.Q change: within $\pm 30\%$ of initial value	1. Test device shall be soldered on the substrate. 2. Oscillation frequency: 10 to 55 to 10Hz for 1min. 3. Amplitude: 1.5mm 4. Time: 2hrs for each axis(X, Y & Z), total 6hrs
1-2-2	Resistance TO Soldering Heat	Appearance: No Damage	1. The device should be reflow soldered on PCB (peak 260 $^{\circ}\text{C}$ \pm 5 $^{\circ}\text{C}$ for 10 seconds) 2. Solder Composition: Sn/Ag3.0/Cu0.5 3. Test time: 6 minutes
1-2-3	Solder ability	The electrodes shall be at least 95% covered with new solder coating	1. Pre-Heating: 150 $^{\circ}\text{C}$, 1min. 2. Solder Composition: Sn/Ag3.0/Cu0.5 3. Solder Temperature: 245 \pm 5 $^{\circ}\text{C}$. 4. Immersion Time: 4 \pm 1 sec.
1-2-4	Component Adhesion (Push Test)	1 Lbs. For 0402 2 Lbs. For 0603 4 Lbs. For The Rest	The device should be reflow soldered (245 \pm 5 $^{\circ}\text{C}$ For 10 seconds) to a tinned copper substrate. A force gauge should be applied to the side of the component. The device must withstand a minimum force of 2 or 4 pounds without a failure of the termination attached to component

BWHP00110706 Series Specification

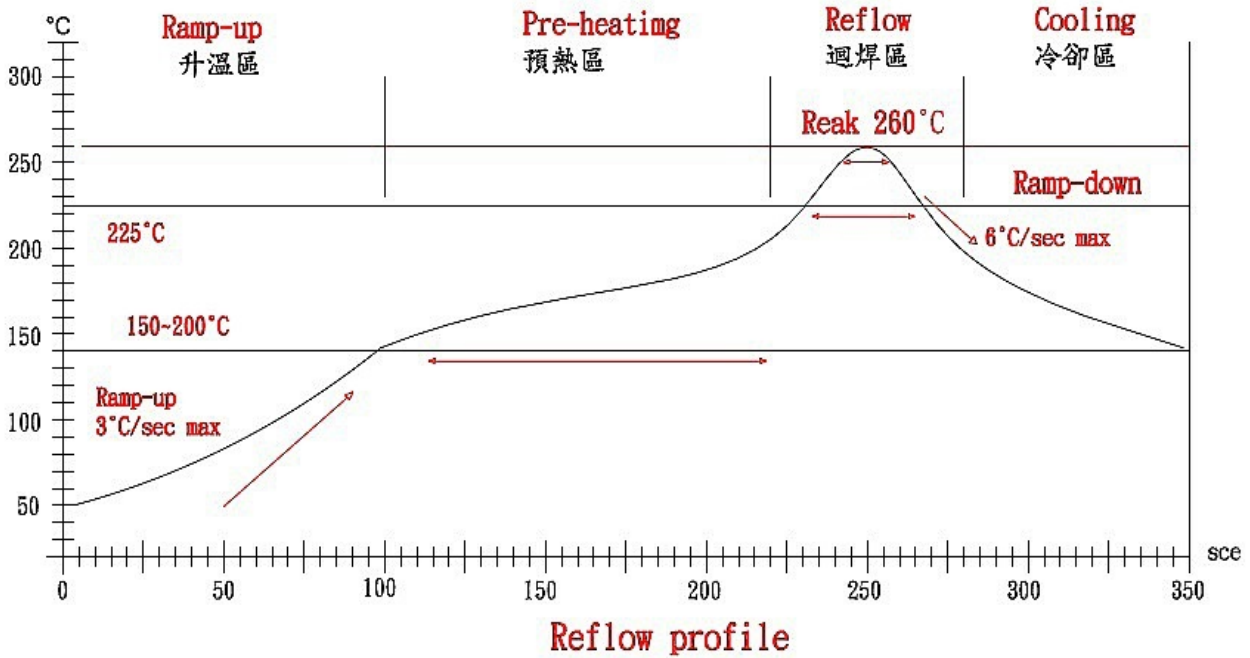

Lead-Free(LF)標準溫度分析範圍

Refer to J-STD-020C

管制項目 Item.	升溫區 Ramp-up	預熱區 Pre-heating	迴焊區 Reflow	Reak Temp	冷卻區 Cooling
溫度範圍 Temp. scope	R. T. ~150°C	150°C ~200°C	Above 217°C	260±5°C	Reak Temp. ~150°C
實際時間 Time result	—	60~180 sec	20~60 sec	5~10 sec	—

NOTE:

- 1.Re-flow possible times : within 3 times
- 2.Nitrogen adopted is recommends while in re-flow
- 3.Products can only be soldered with reflow

BWHP00110706 Series Specification

10 Packaging:

10.1 Packaging -Cover Tape

The force for tearing off cover tape is 10 to 100 grams in the arrow direction.

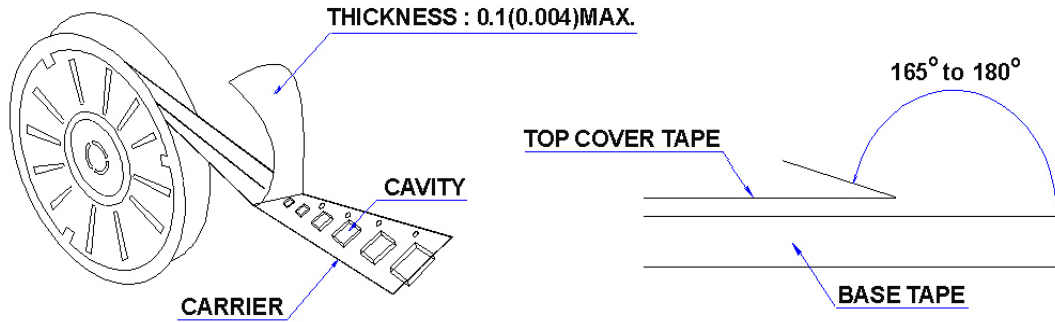

10.2 Packaging Quantity

TYPE	PCS/REEL
110706	4000

10.3 Reel Dimensions

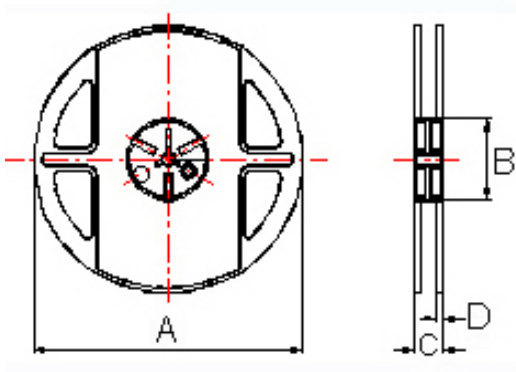

Dimensions in mm

TYPE	A	B	C	D
110706	178±1	60±0.5	12±0.5	1.5±0.5

BWHP00110706 Series Specification

10 Packaging:

10.4 Tape Dimensions in mm

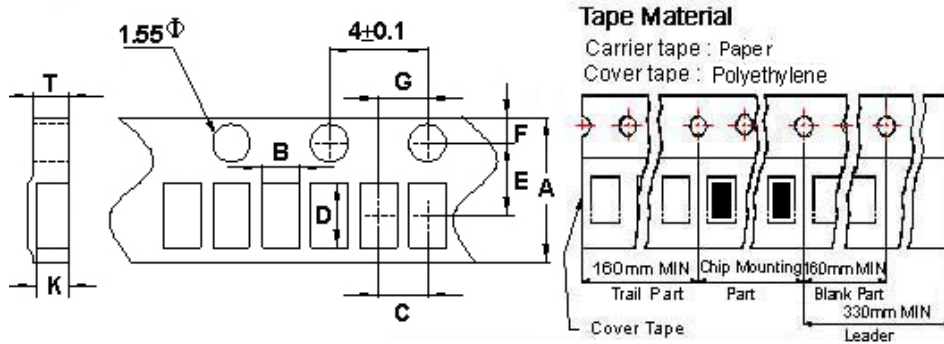

TYPE	A	B	C	D	E	F	G	T	K
110706	8.0	0.80	2	1.20	3.5	1.75	2	0.75	0.62

11 Recommended Land Pattern:

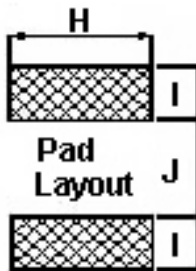

Dimensions in mm

TYPE	H(In/mm)	I(In/mm)	J(In/mm)
110706	0.026/0.66	0.014/0.36	0.020/0.51

12 Note:

- Please make sure that your product has been evaluated and confirmed against your specifications when our product is mounted to your product.
- Do not knock nor drop.
- All the items and parameters in this product specification have been prescribed on the premise that our product is used for the purpose, under the condition and in the environment agreed upon between you and us. You are requested not to use our product deviating from such agreement.
- The storage period is less than 12 months. Be sure to follow the storage conditions (Temperature: 5 to 40°C, Humidity: 10 to 75% RH or less).
If the storage period elapses, the soldering of the terminal electrodes may deteriorate.
- Do not use or store in locations where there are conditions such as gas corrosion (salt, acid, alkali, etc.).
- The moisture sensitivity level (MSL) of products is classified as level 1.

BWHP00110706 Series Specification

13 Graph:

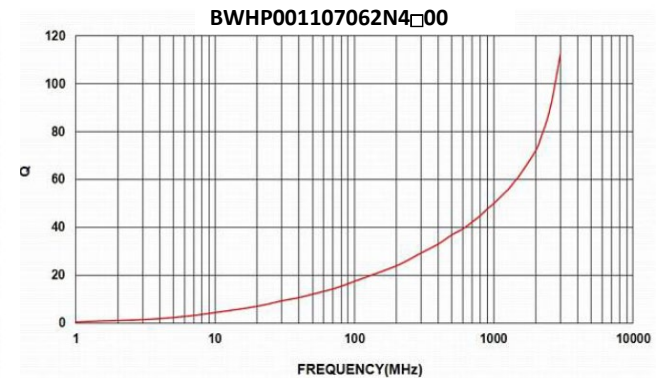
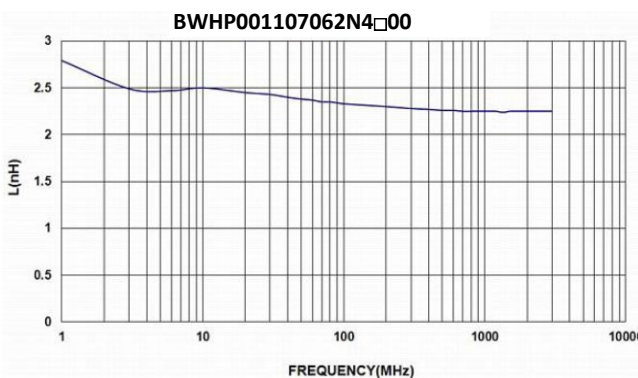
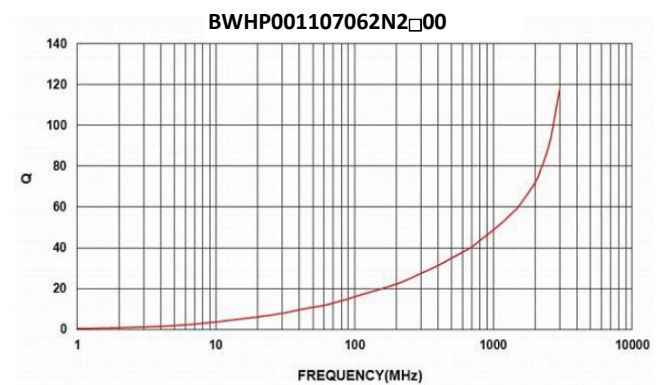
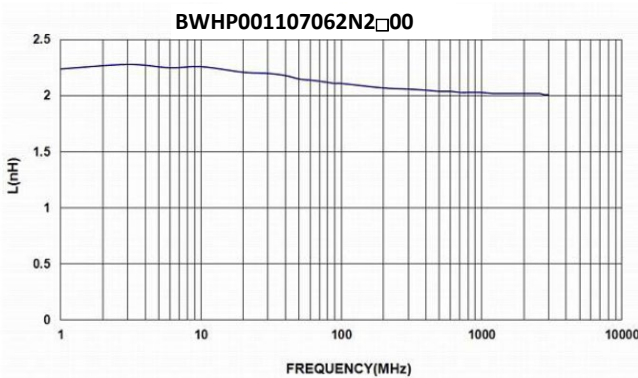
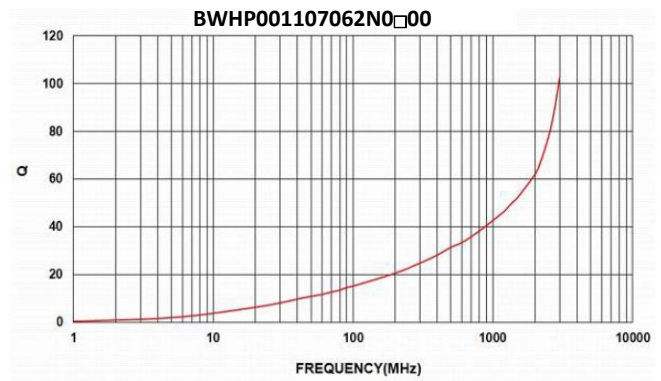
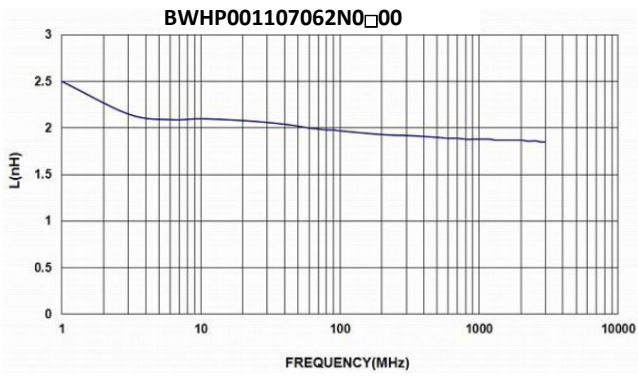
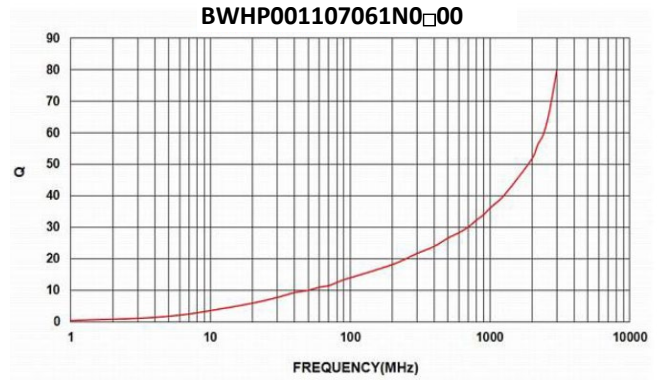
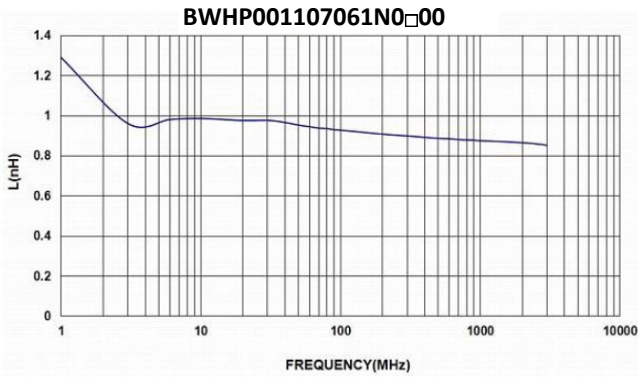

BWHP00110706 Series Specification

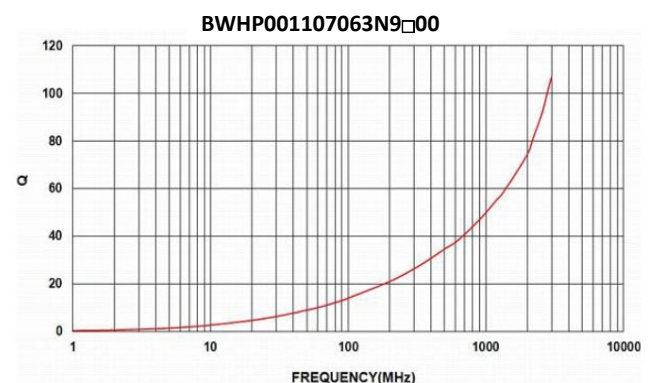
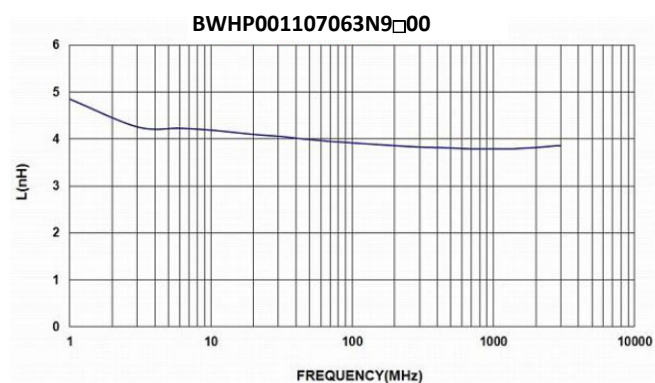
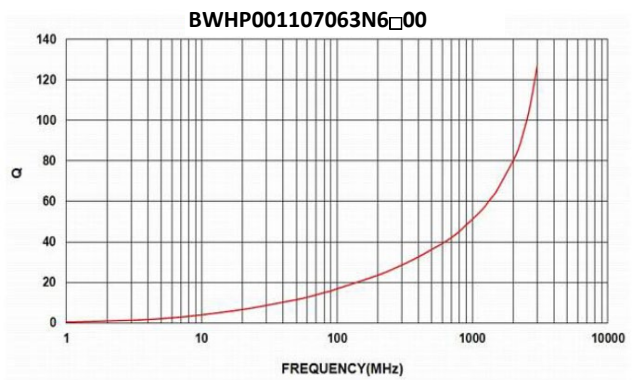
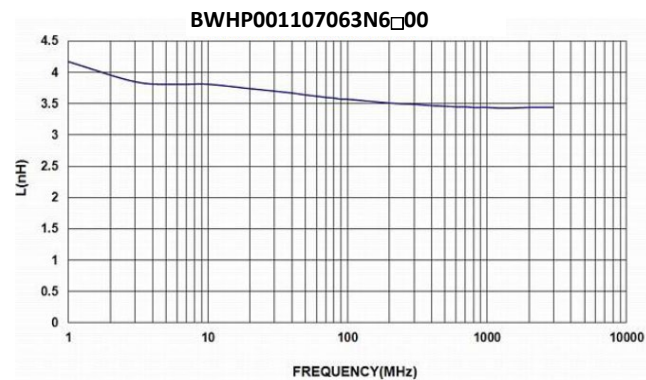
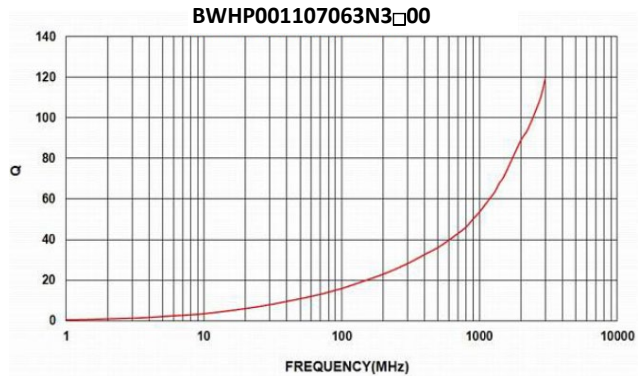
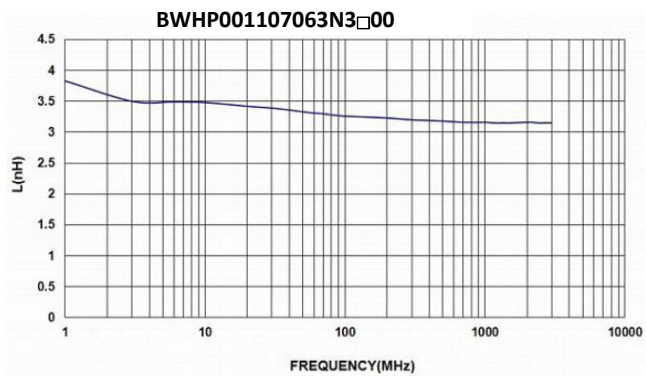
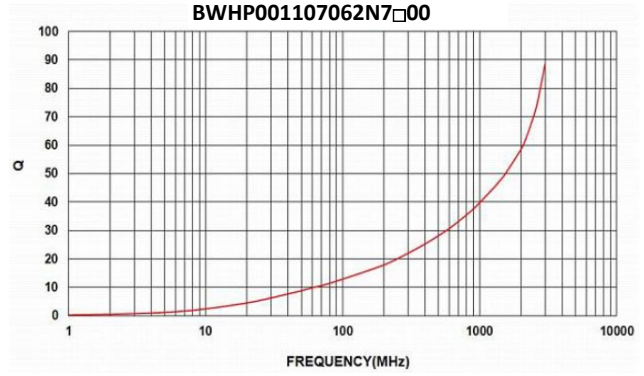
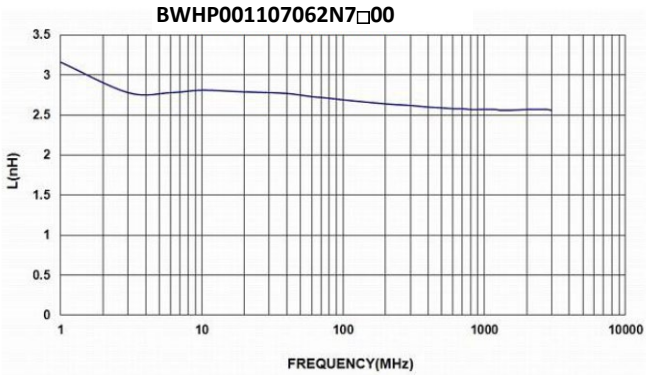

BWHP00110706 Series Specification

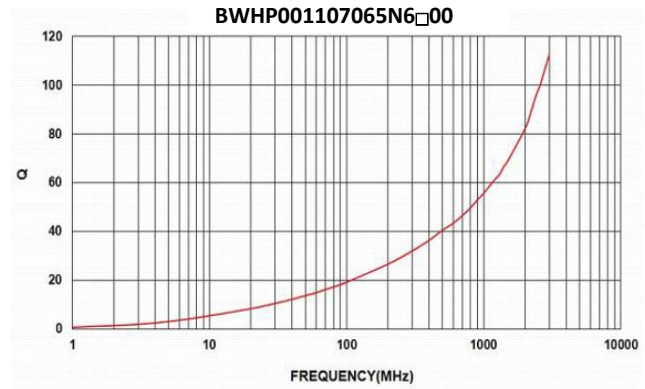
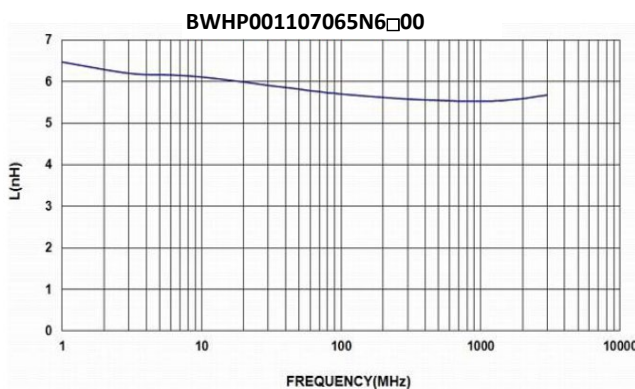
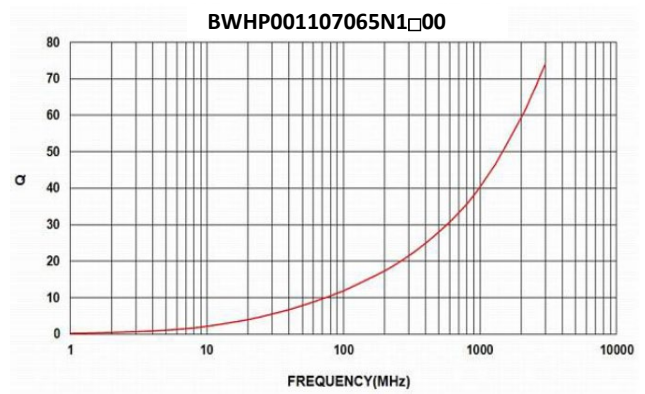
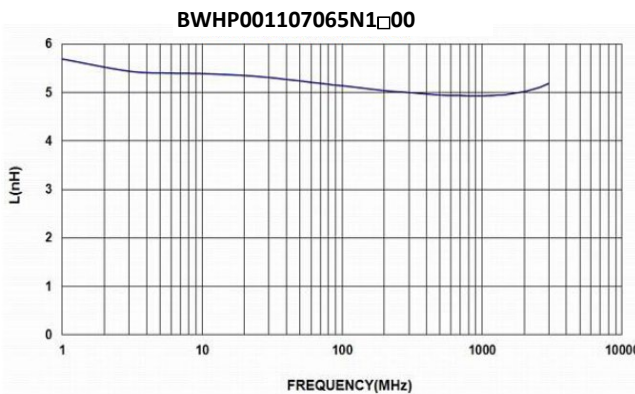
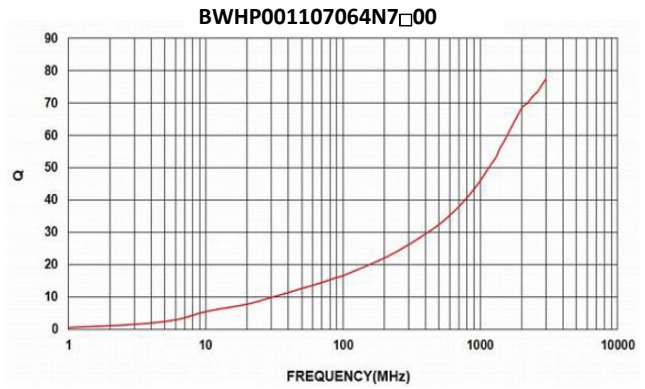
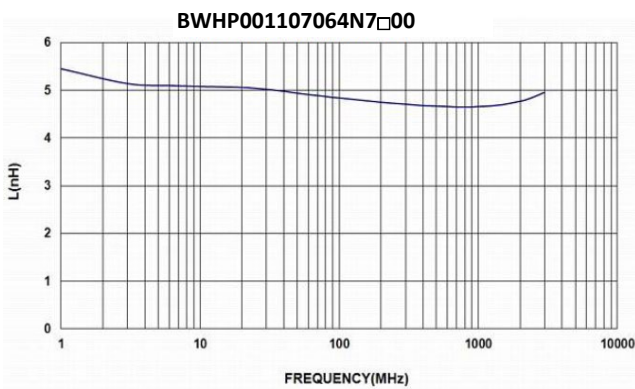
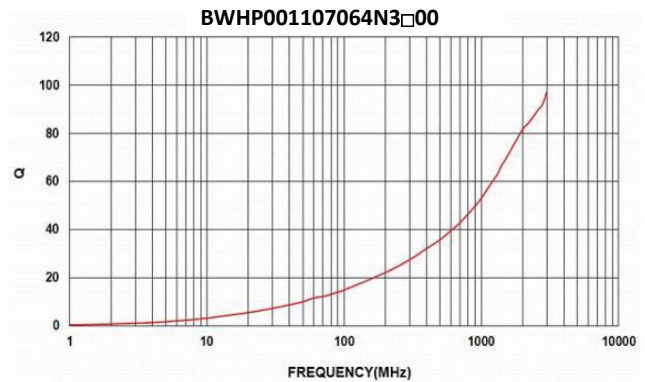
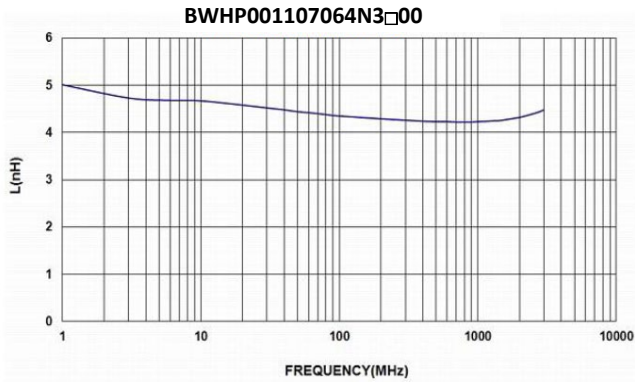

BWHP00110706 Series Specification

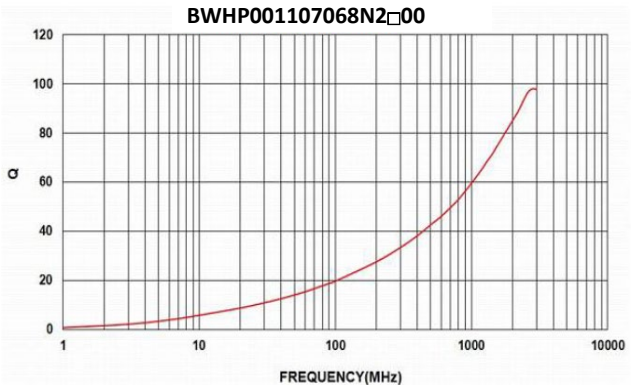
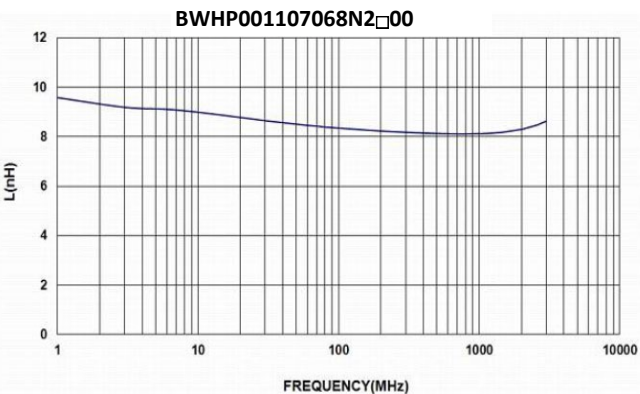
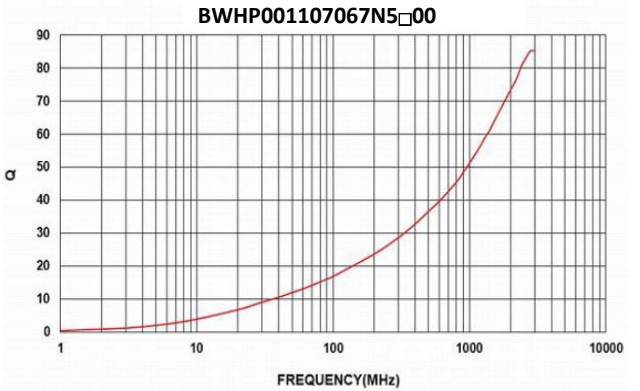
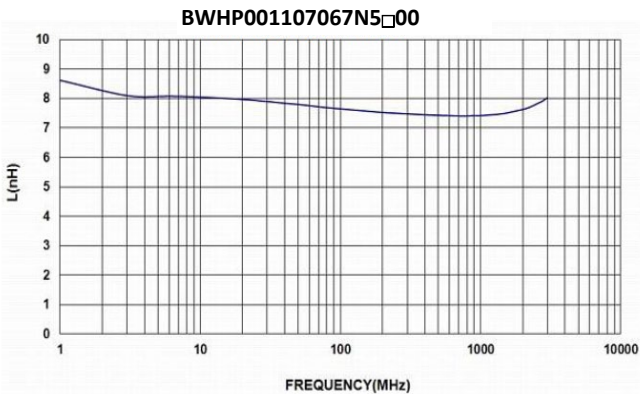
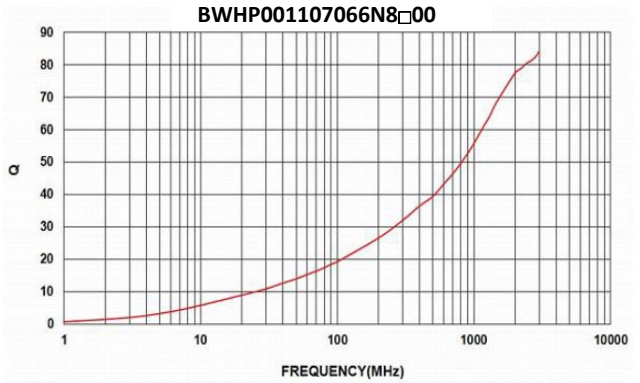
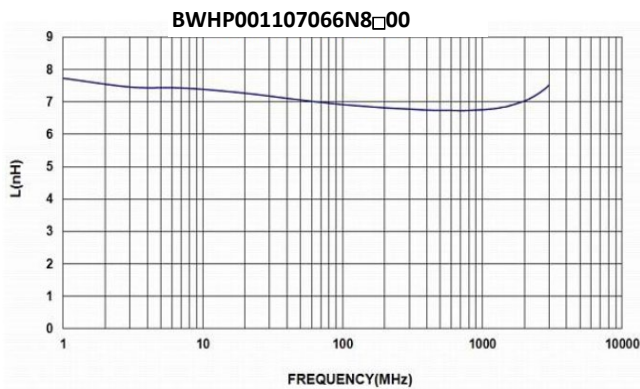
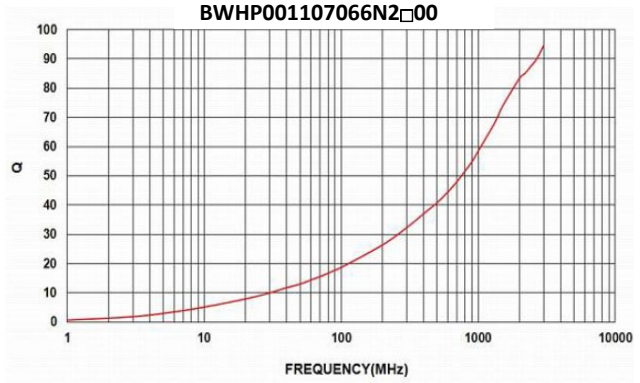
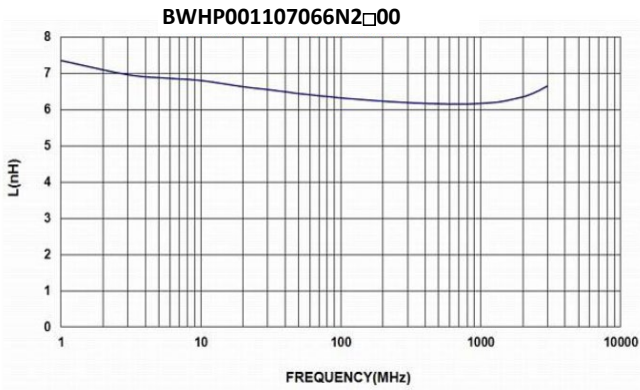

BWHP00110706 Series Specification

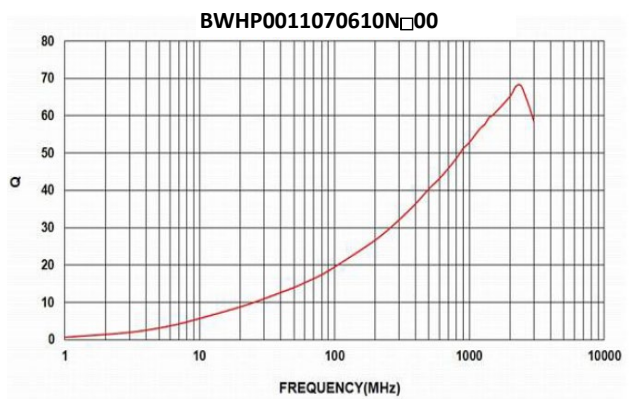
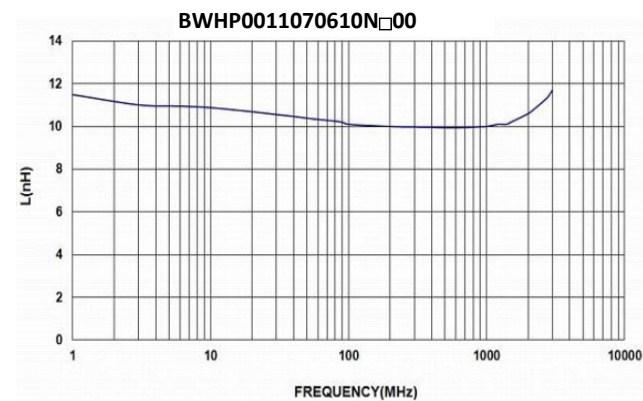
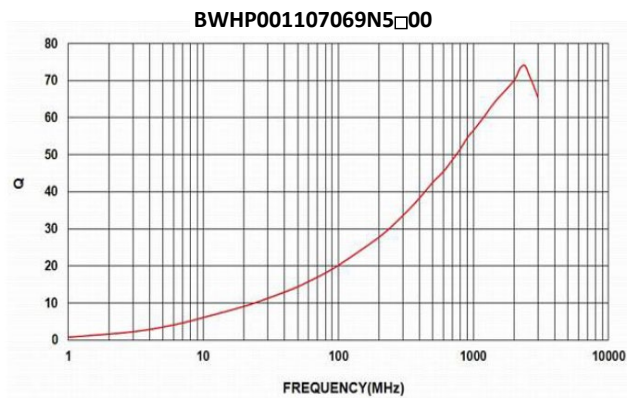
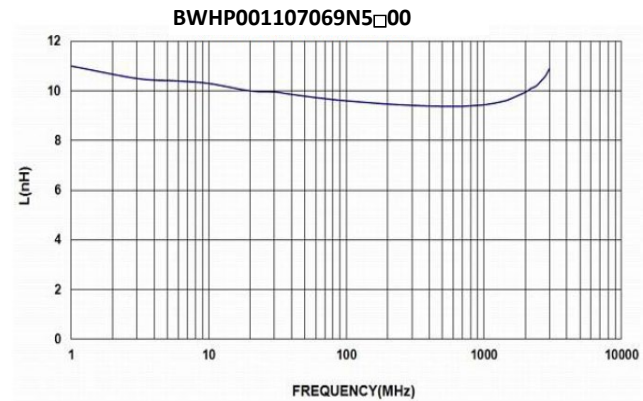
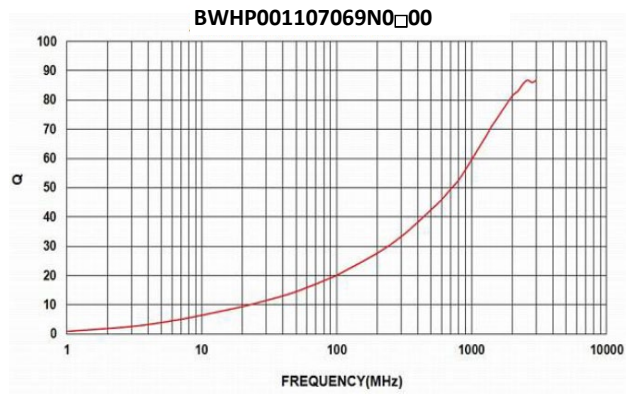
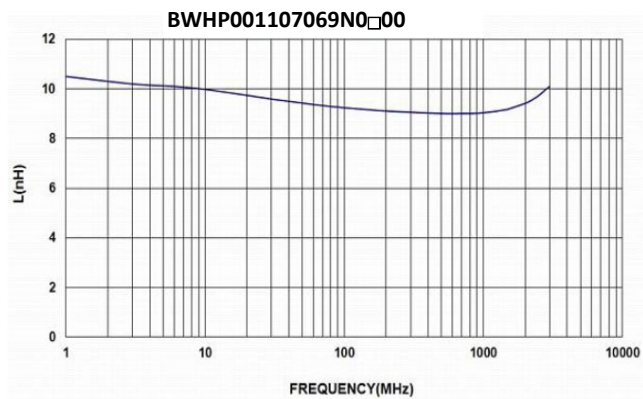
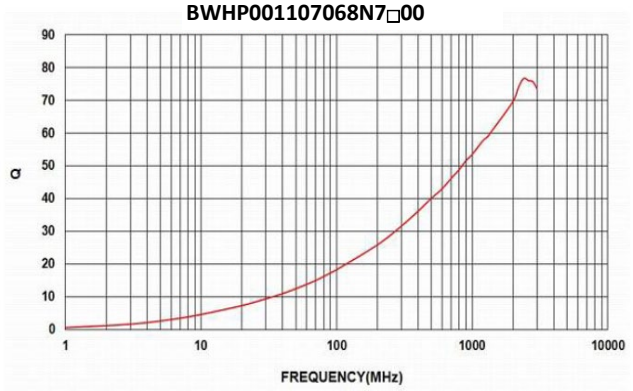
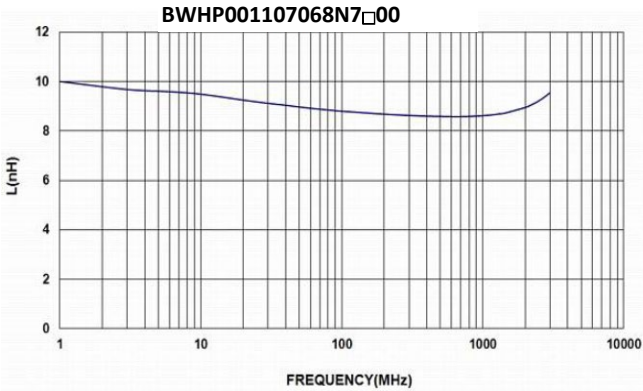

BWHP00110706 Series Specification

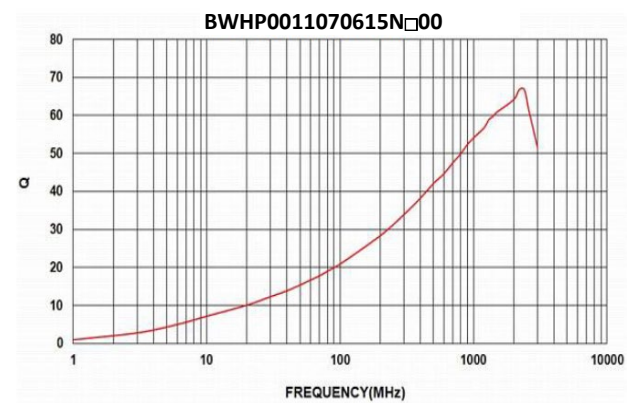
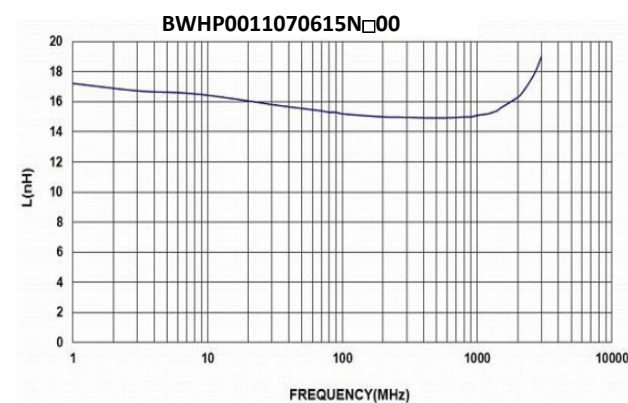
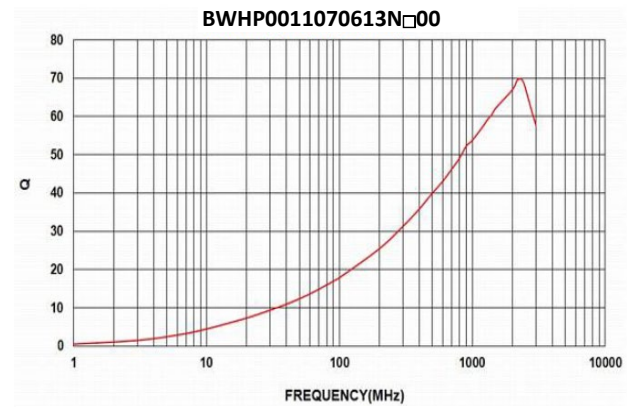
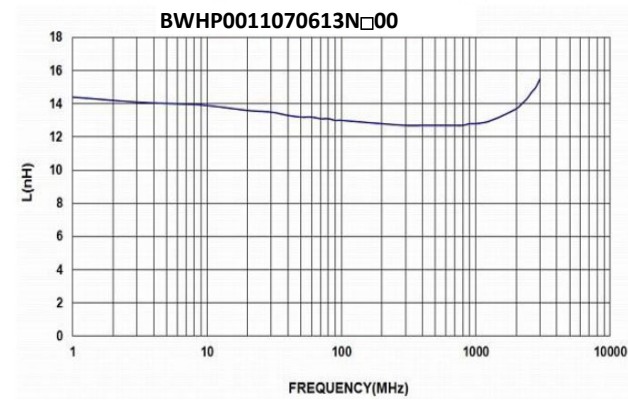
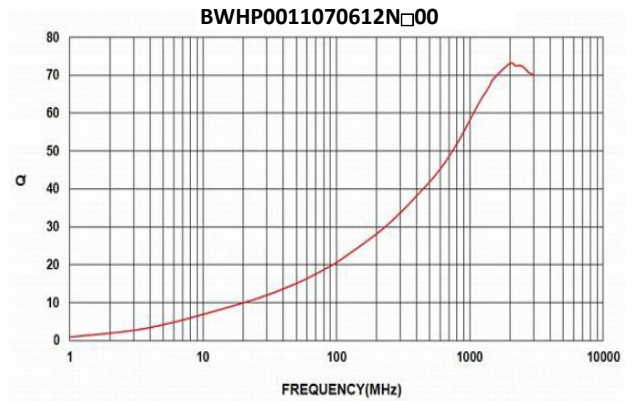
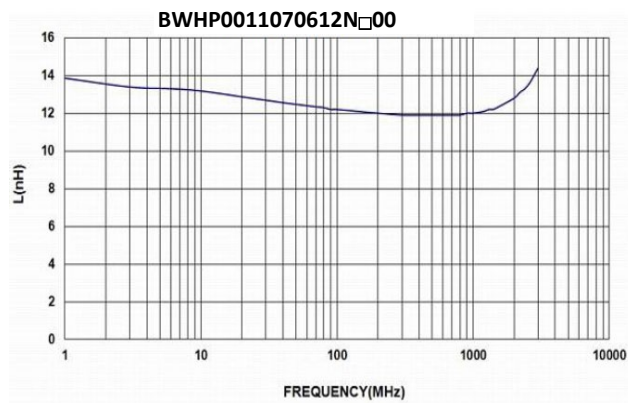
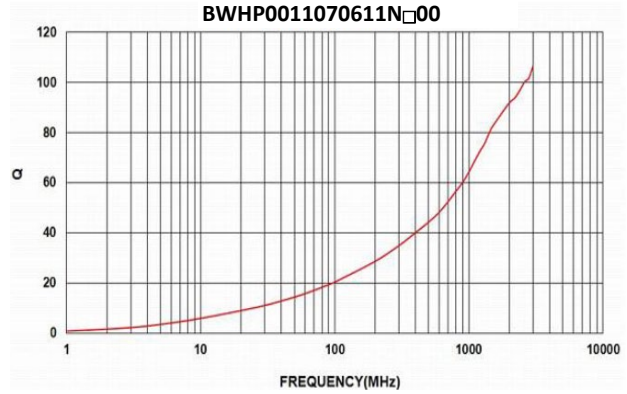
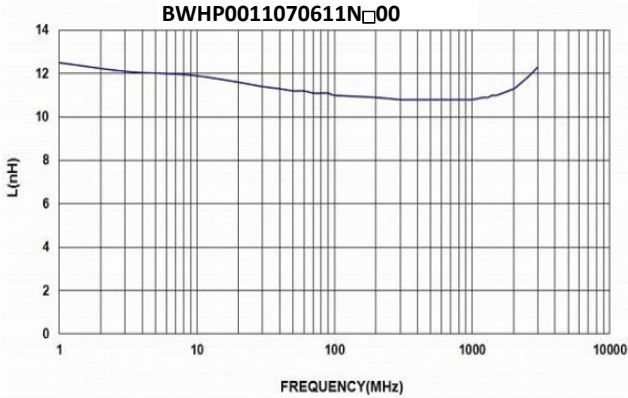

BWHP00110706 Series Specification

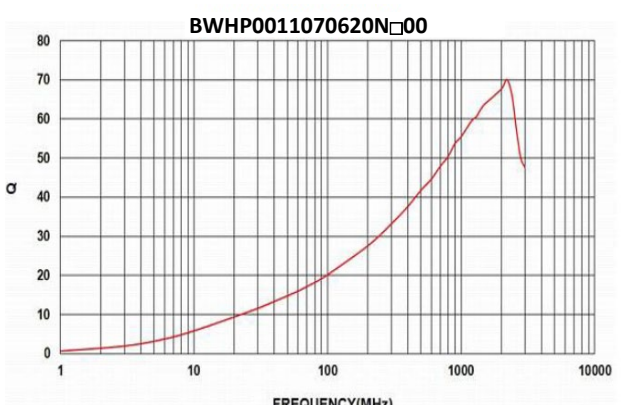
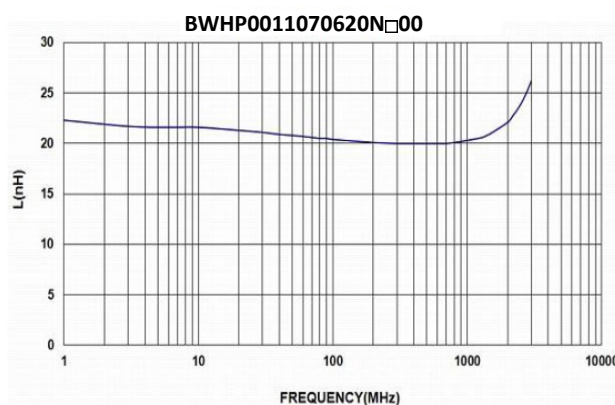
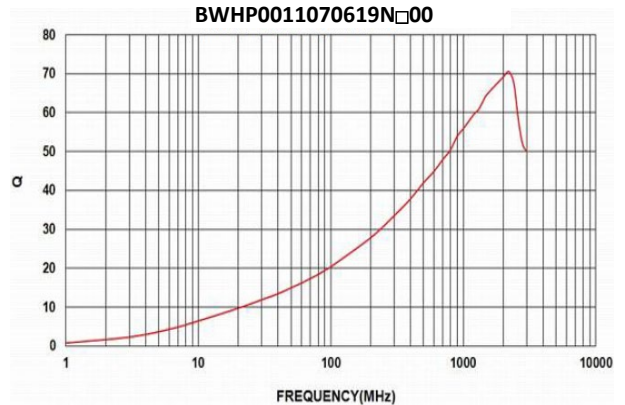
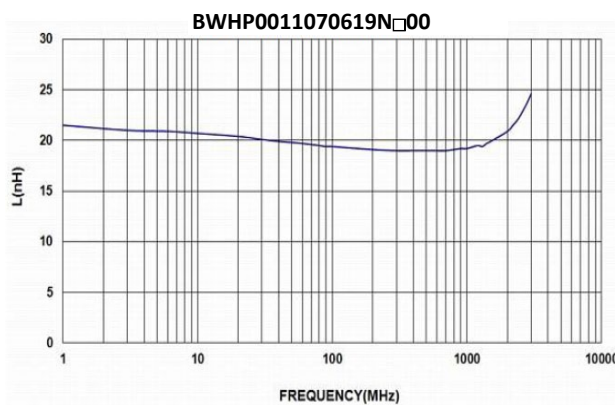
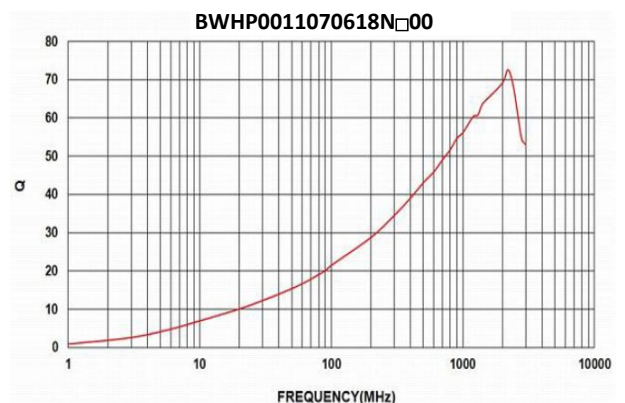
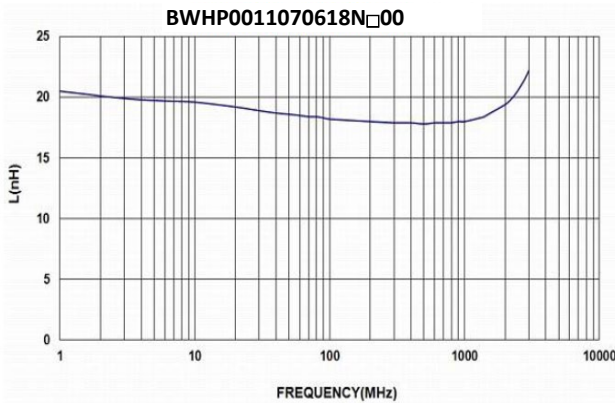
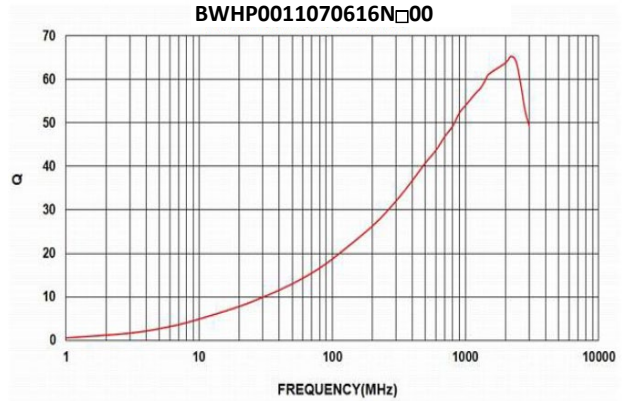
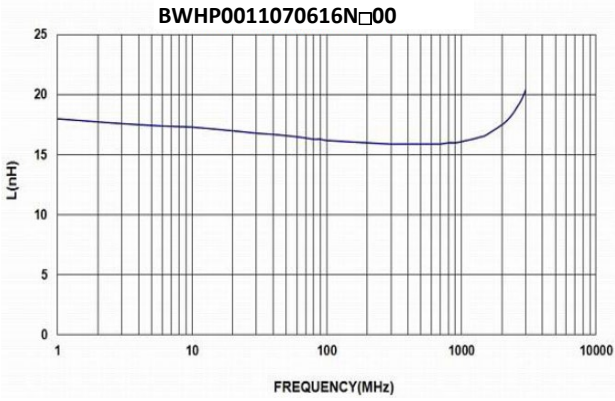

BWHP00110706 Series Specification

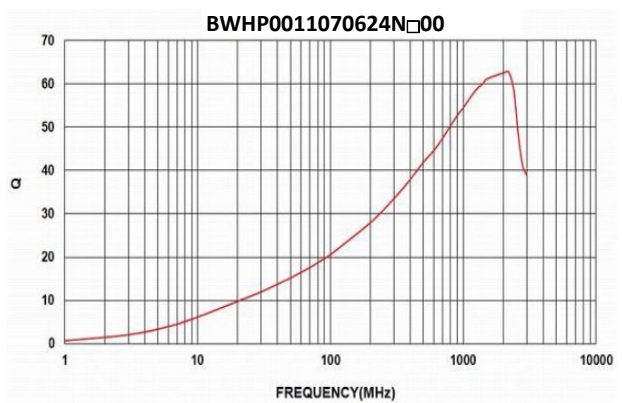
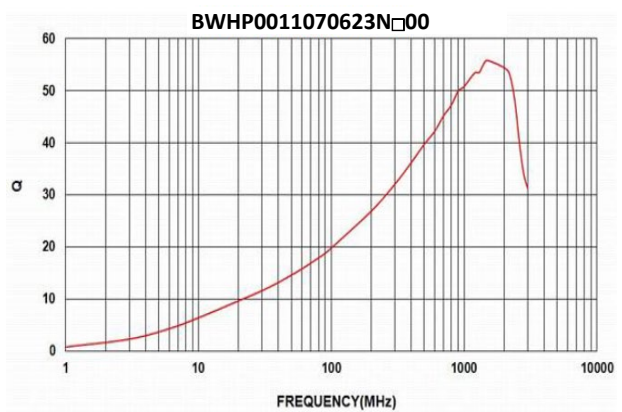
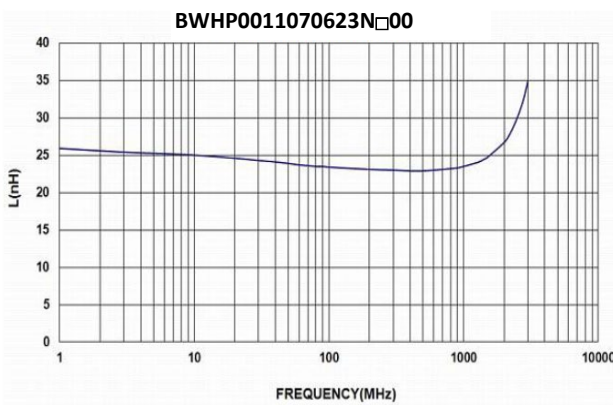
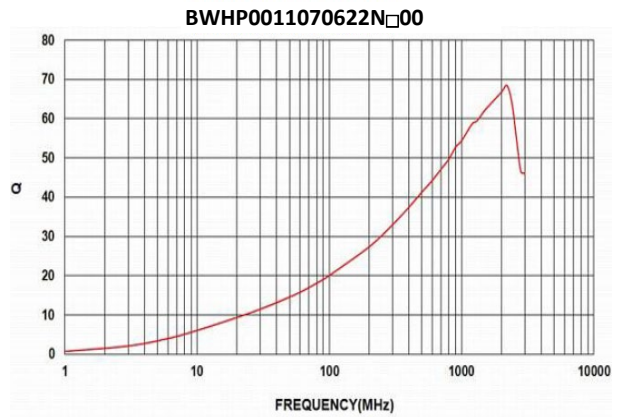
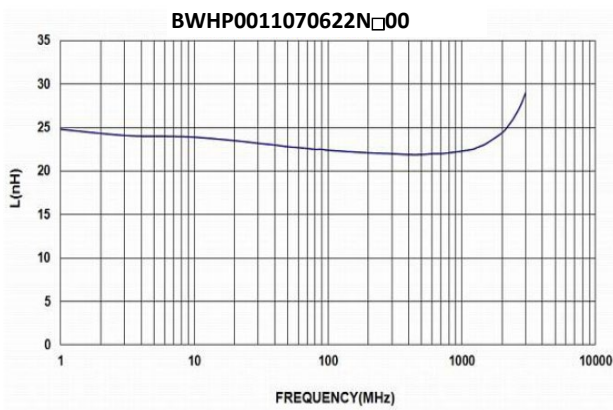
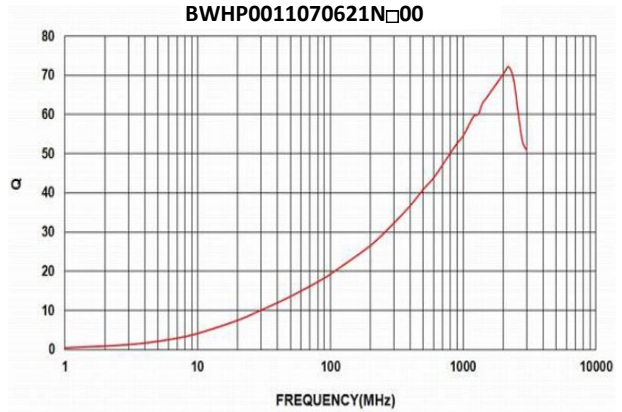
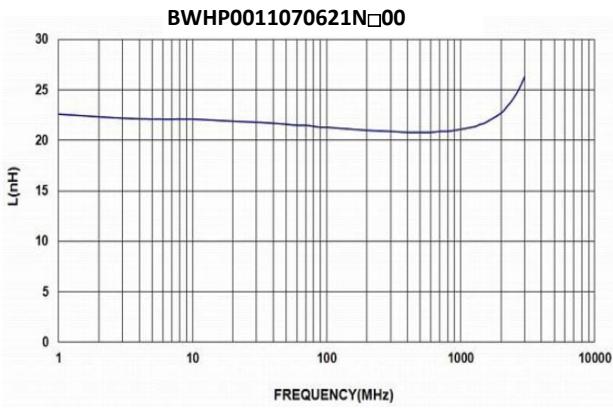

BWHP00110706 Series Specification

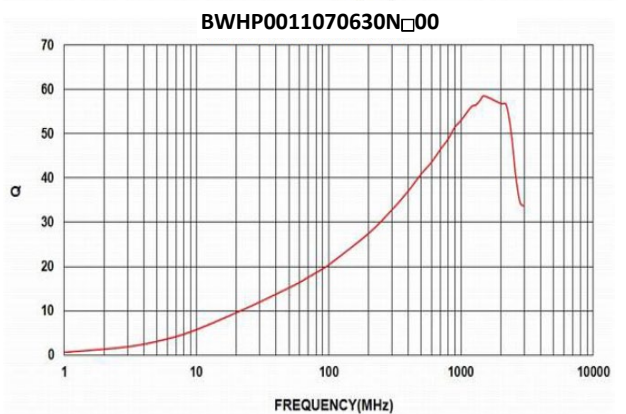
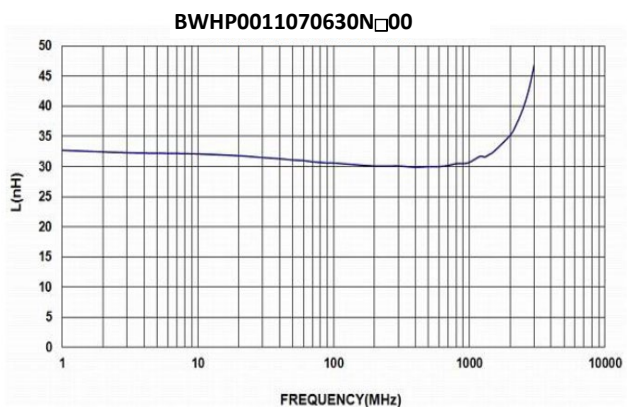
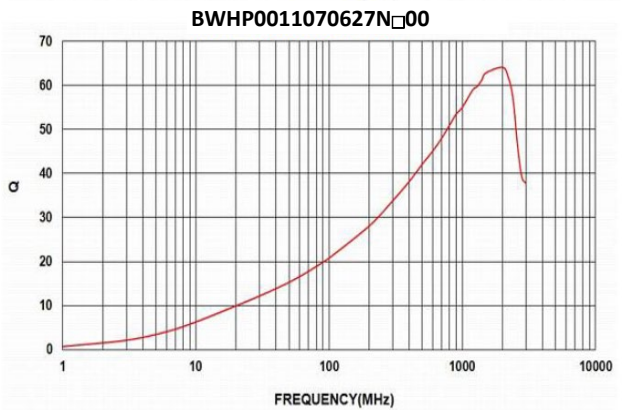
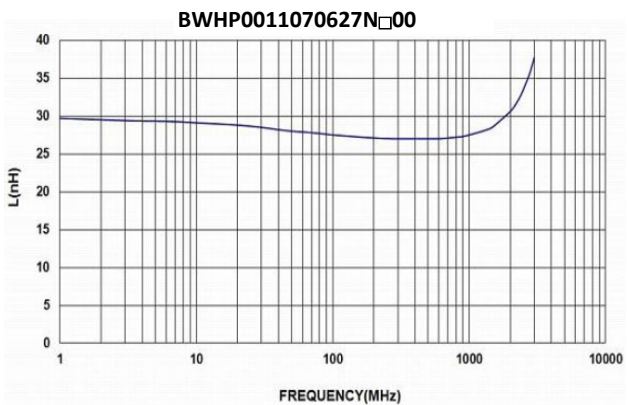
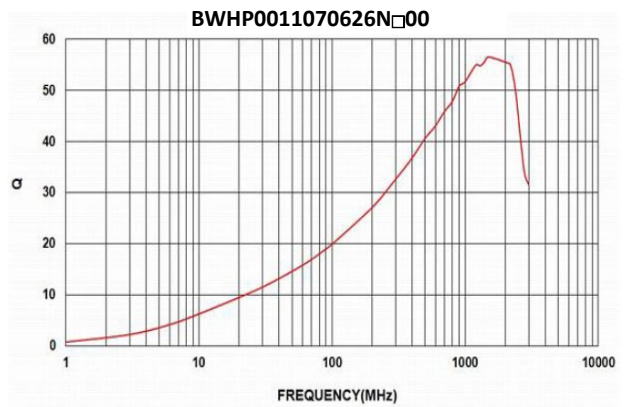
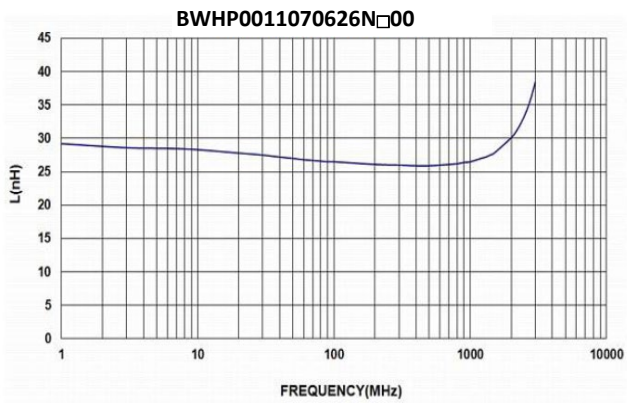
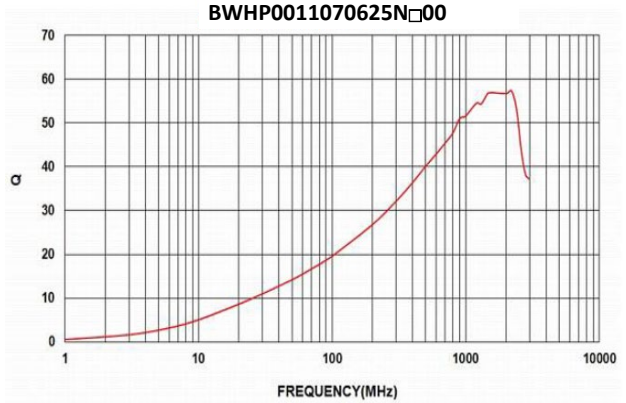
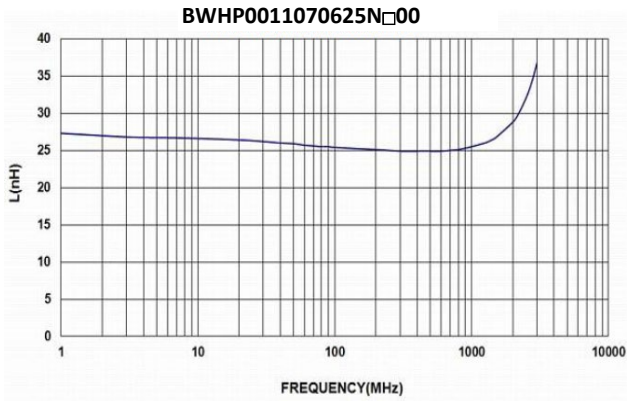

BWHP00110706 Series Specification

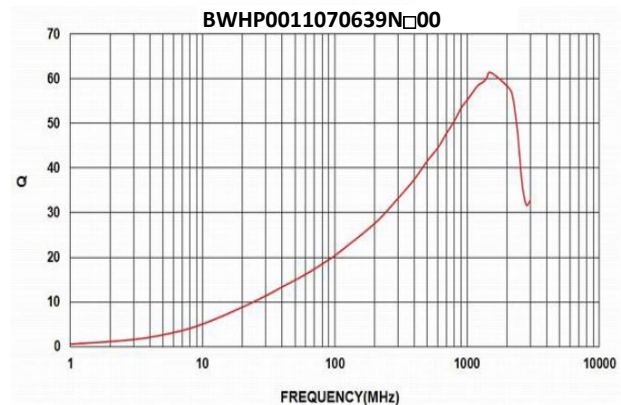
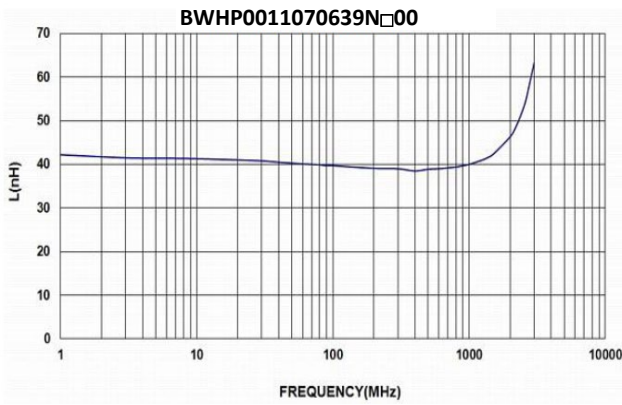
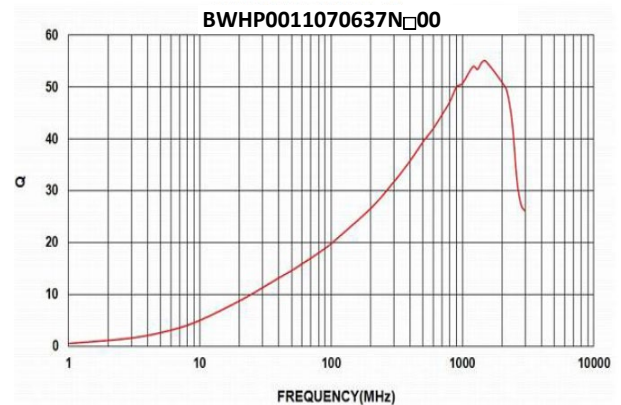
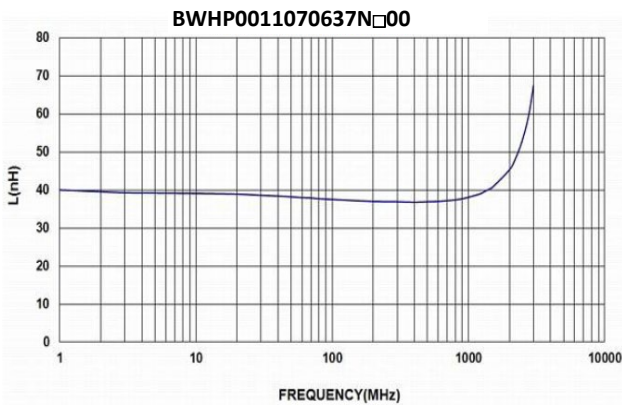
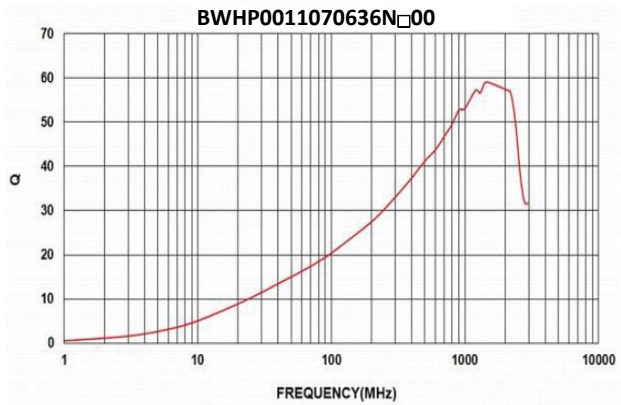
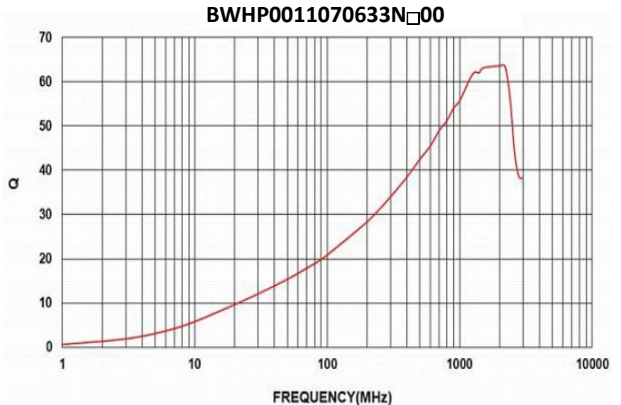
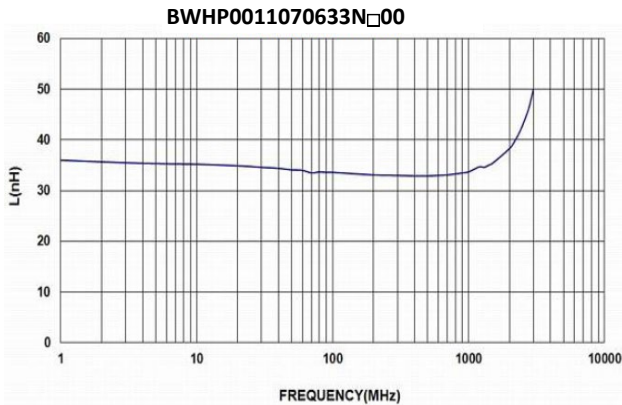

BWHP00110706 Series Specification

