

Power Inductor

BPSD Series



Overview

Power inductors are passive electronic components used in various circuits to store energy in a magnetic field when electrical current flows through them. They are critical in filtering, energy storage, and noise suppression in power electronic systems. They are designed to handle higher currents and are optimized for minimal power loss and thermal efficiency.

Benefits

1. Ferrite SMD Shielded Type
2. Unshielded power inductor
3. Various package size and wide inductance range

Applications

1. Graphic cards
2. DC/DC converters

Product Information

Series	L (mm)	W(mm)	T (mm)	Inductance (μH)
BPSD	3.3	3.0	1.5	0.15 ~ 8200
	3.3	3.0	2.1	
	4.5	4.0	3.2	
	5.8	5.2	2.5	
	5.8	5.2	3.0	
	5.8	5.2	4.5	
	7.8	7.0	3.5	
	7.8	7.0	5.0	
	10	9.0	4.0	
	10	9.0	5.4	
	10	9.0	6.5	



BPSD00060545 Series Specification

6 Configuration and Dimensions and Unit Weight:

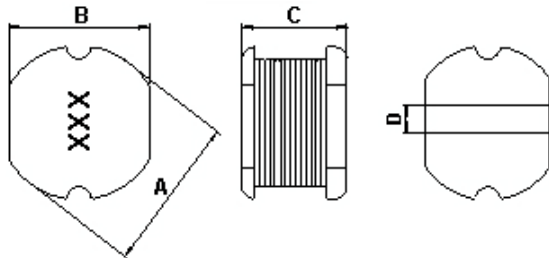

Dimensions in mm

TYPE	060545
A	5.8±0.3
B	5.2±0.3
C	4.5±0.4
D	1.3

Net Weight (grms)

SIZE CODE	Net Weight (grms)
060545	0.5(Typ.)

7 Electrical Characteristics:

Part No.	Inductance (uH)	Test Freq.	RDC (Ω)Max.	Isat (A)	Irms (A)	Tolerance (±%)	Marking
BPSD000605451R8□00	1.8	7.96 MHz,1 V	0.02	3.5	3.5	20	1R8
BPSD000605452R2□00	2.2	7.96 MHz,1 V	0.023	3.2	3.2	20	2R2
BPSD000605453R3□00	3.3	7.96 MHz,1 V	0.0314	2.59	2.59	10,20	3R3
BPSD000605453R5□00	3.5	7.96 MHz,1 V	0.03	2.4	2.4	20	3R5
BPSD000605454R7□00	4.7	7.96 MHz,1 V	0.0372	2.3	2.3	10,20	4R7
BPSD000605456R8□00	6.8	7.96 MHz,1 V	0.057	1.8	1.8	20	6R8
BPSD000605458R2□00	8.2	7.96 MHz,1 V	0.0594	1.7	1.7	20	8R2
BPSD00060545100□00	10	2.52 MHz,1 V	0.1	1.44	1.44	10,20	100
BPSD00060545120□00	12	2.52 MHz,1 V	0.12	1.4	1.4	20	120
BPSD00060545150□00	15	2.52 MHz,1 V	0.14	1.3	1.3	10,20	150
BPSD00060545180□00	18	2.52 MHz,1 V	0.15	1.23	1.23	20	180
BPSD00060545220□00	22	2.52 MHz,1 V	0.18	1.11	1.11	20	220
BPSD00060545270□00	27	2.52 MHz,1 V	0.2	0.97	0.97	20	270
BPSD00060545330□00	33	2.52 MHz,1 V	0.23	0.88	0.88	10,20	330
BPSD00060545390□00	39	2.52 MHz,1 V	0.32	0.8	0.8	10,20	390
BPSD00060545470□00	47	2.52 MHz,1 V	0.37	0.72	0.72	10,20	470
BPSD00060545560□00	56	2.52 MHz,1 V	0.42	0.68	0.68	10,20	560
BPSD00060545680□00	68	2.52 MHz,1 V	0.46	0.61	0.61	10,20	680
BPSD00060545820□00	82	2.52 MHz,1 V	0.6	0.58	0.58	10,20	820
BPSD00060545101□00	100	1 kHz,1 V	0.7	0.52	0.52	10,20	101
BPSD00060545121□00	120	1 kHz,1 V	0.93	0.48	0.48	10,20	121
BPSD00060545151□00	150	1 kHz,1 V	1.1	0.4	0.4	10,20	151
BPSD00060545181□00	180	1 kHz,1 V	1.38	0.38	0.38	10,20	181
BPSD00060545221□00	220	1 kHz,1 V	1.57	0.35	0.35	10,20	221
BPSD00060545271□00	270	1 kHz,1 V	1.85	0.29	0.29	10,20	271

NOTE: □-tolerance K=±10% / M=±20%

1. Operating temperature range - 4 0 °C ~ 1 2 5 °C(Including self - temperature rise)
2. Isat for Inductance drop 10% from its value without current.
3. I rms for a 40 °C temperature rise from 25 °C ambient.

BPSD00060545 Series Specification

Part No.	Inductance (μ H)	Test Freq.	RDC (Ω)Max.	Isat (A)	Irms (A)	Tolerance (\pm %)	Marking
BPSD00060545331□00	330	1 kHz,1 V	2	0.28	0.28	10,20	331
BPSD00060545391□00	390	1 kHz,1 V	2.6	0.26	0.26	10,20	391
BPSD00060545471□00	470	1 kHz,1 V	3	0.12	0.12	10,20	471
BPSD00060545561□00	560	1 kHz,1 V	4.19	0.1	0.1	10,20	561
BPSD00060545681□00	680	1 kHz,1 V	4.44	0.08	0.08	10,20	681
BPSD00060545821□00	820	1 kHz,1 V	5.12	0.05	0.05	10,20	821
BPSD00060545102□00	1000	1 kHz,1 V	10	0.03	0.03	10,20	102
BPSD00060545152□00	1500	1 kHz,1V	11	0.03	0.03	10,20	152
BPSD00060545182□00	1800	1 kHz,1V	12.3	0.03	0.03	10,20	182
BPSD00060545202□00	2000	1 kHz,1V	12.6	0.03	0.03	10,20	202
BPSD00060545222□00	2200	1 kHz,1V	12.9	0.03	0.03	10,20	222

BPSD00060545 Series Specification

8 BPSD00060545 Series

8.1 Construction:

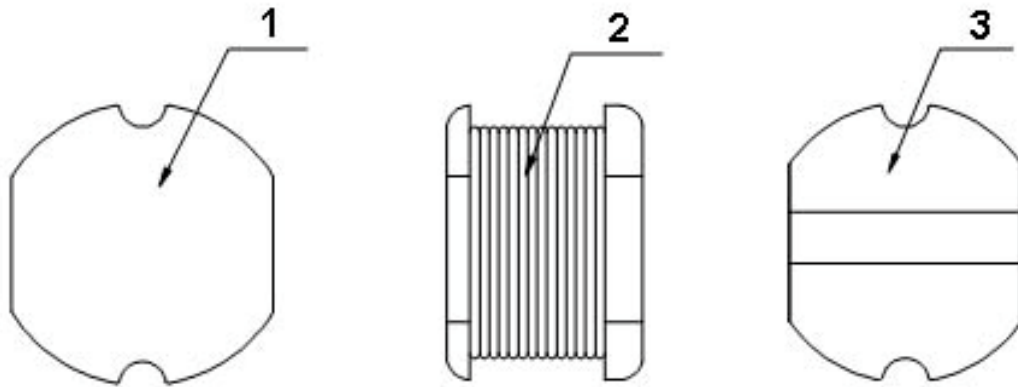

8.2 Material List:

No	Part	Material
1	CORE	FERRITE
2	WIRE	MAGNET WIRE
3	TERMINAL	Ag/Ni/Sn

BPSD00060545 Series Specification

9 Reliability Of Ferrite Wire Wound Power Inductor

1-1.Mechanical Performance

No	Item	Specification	Test Method
1-1-1	Vibration	Appearance: No damage Inductance: within $\pm 10\%$ of initial value	Test device shall be soldered on the substrate Oscillation Frequency: 10 to 55 to 10Hz for 1min Amplitude: 1.5mm Time: 2hrs for each axis (X, Y & Z), total 6hrs
1-1-2	Resistance to Soldering Heat	Appearance: No damage	Pre-heating: 150°C, 1min Solder Composition: Sn/Ag3.0/Cu0.5 Solder Temperature: 260 \pm 5°C Immersion Time: 10 \pm 1sec
1-1-3	Solder ability	The electrodes shall be at least 95% covered with new solder coating	Pre-heating: 150°C, 1min Solder Composition: Sn/Ag3.0/Cu0.5 Solder Temperature: 245 \pm 5°C Immersion Time: 4 \pm 1sec
1-1-4	Resistance to solvent	There must be no change in appearance or obliteration of marking.	Inductors must withstand 6 minutes of alcohol or water.

1-2.Environmental Performance

No	Item	Specification	Test Method															
1-2-1	Temperature Shock	Appearance: No damage Inductance: within $\pm 10\%$ of initial value	10 cycles (Air to Air) 1 cycles shall consist of: 30 minutes exposure to -55 °C 30 minutes exposure to 125 °C 15 seconds maximum transition between temperatures															
1-2-2	Temperature Cycle		One cycle: <table border="1"> <thead> <tr> <th>Step</th> <th>Temperature (°C)</th> <th>Time (min)</th> </tr> </thead> <tbody> <tr> <td>1</td> <td>-40\pm3</td> <td>30</td> </tr> <tr> <td>2</td> <td>25\pm2</td> <td>3</td> </tr> <tr> <td>3</td> <td>125\pm3</td> <td>30</td> </tr> <tr> <td>4</td> <td>25\pm2</td> <td>3</td> </tr> </tbody> </table>	Step	Temperature (°C)	Time (min)	1	-40 \pm 3	30	2	25 \pm 2	3	3	125 \pm 3	30	4	25 \pm 2	3
Step	Temperature (°C)	Time (min)																
1	-40 \pm 3	30																
2	25 \pm 2	3																
3	125 \pm 3	30																
4	25 \pm 2	3																
1-2-3	Humidity Resistance		Total: 100cycles Measured after exposure in the room condition for 24hrs Temperature: 40 \pm 2°C Relative Humidity: 90 ~ 95% Time: 1000hrs Measured after exposure in the room condition for 24hrs															
1-2-4	Heat Life		Temperature: 85 \pm 3°C Applied Current: Rated Current Time: 1000hrs Measured after exposure in the room condition for 24hrs															
1-2-5	Cold Resistance		Temperature: -40 \pm 3°C Time: 1000hrs Measured after exposure in the room condition for 24hrs															

BPSD00060545 Series Specification

Reflow Soldering Profile

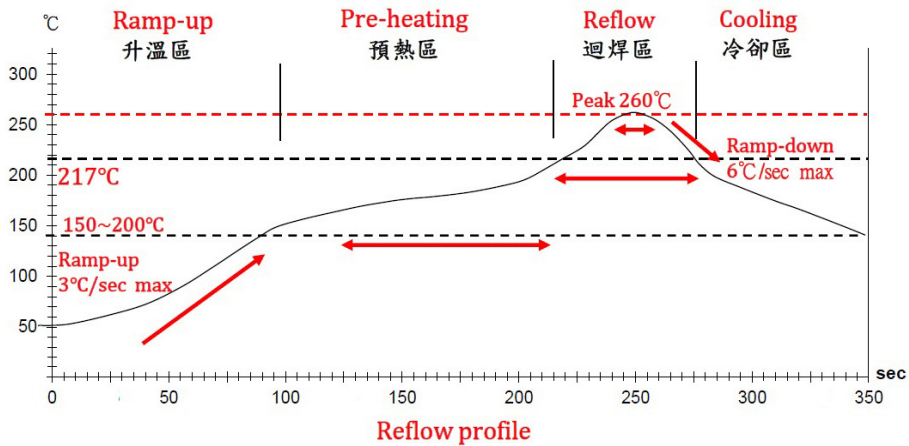

Lead-Free(LF)標準溫度分析範圍

Refer to J-STD-020C

管制項目 Item.	升溫區 Ramp-up	預熱區 Pre-heating	迴焊區 Reflow	Peak Temp	冷卻區 Cooling
溫度範圍 Temp.scope	R.T ~ 150°C	150°C ~ 200°C	217°C	260±5°C	Peak Temp.~150°C
標準時間 Time spec.	-	60 ~ 180 sec	60 ~ 150 sec	20 ~ 40 sec	-
實際時間 Time result	-	75 ~ 100 sec	90 ~ 120 sec	20 ~ 35 sec	-

BPSD00060545 Series Specification

11 Packaging:

11.1 Packaging -Cover Tape

The force for tearing off cover tape is 10 to 130 grams in the arrow direction.

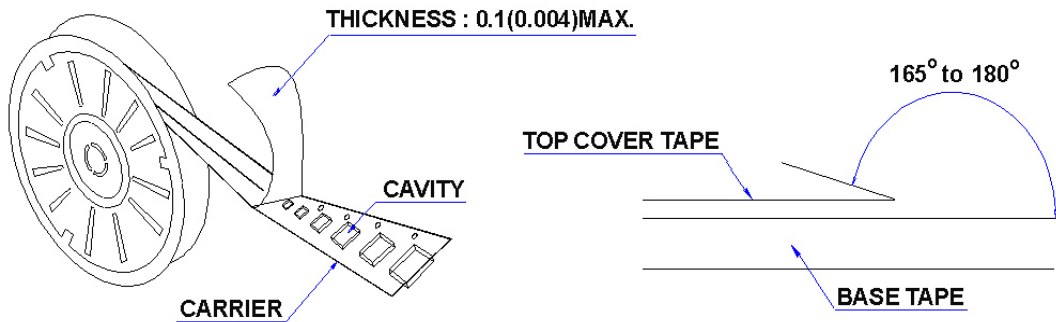

11.2 Packaging Quantity

TYPE	PCS/REEL
060545	1500

11.3 Reel Dimensions

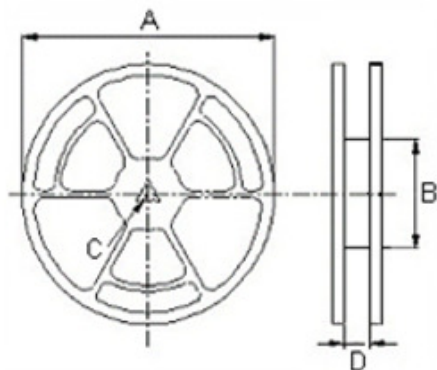

Dimensions in mm

TYPE	A	B	C	D
060545	330	100	13	16

BPSD00060545 Series Specification

11 Packaging:

11.4 Tape Dimensions in mm

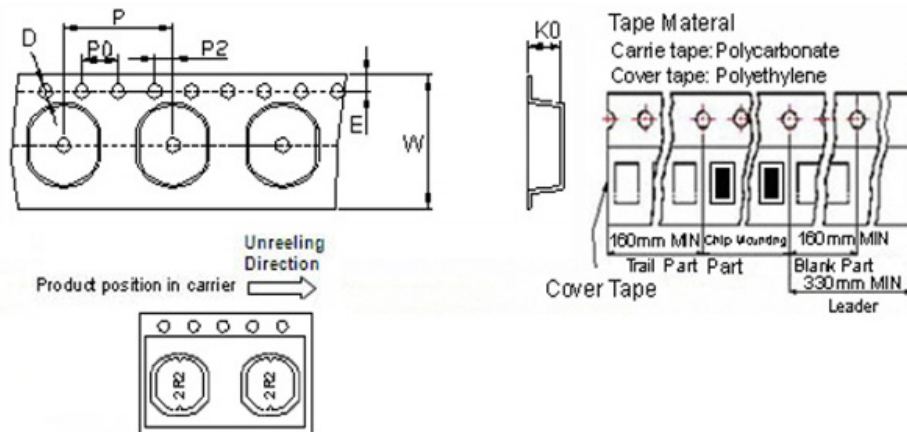

TYPE	K0	D	E	W	P	P0	P2
060545	4.80	1.55	1.75	16	8	4	2

12 Recommended Land Pattern:

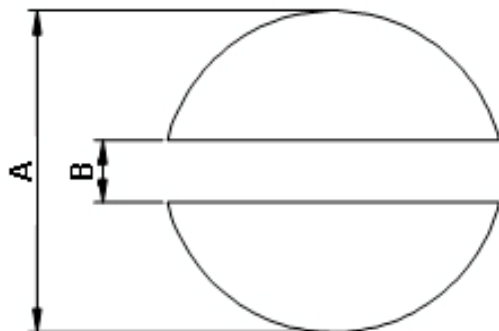

Dimensions in mm

TYPE	A	B
060545	6.8	1.3

13 Note:

1. Please make sure that your product has been evaluated and confirmed against your specifications when our product is mounted to your product.
2. Do not knock nor drop.
3. All the items and parameters in this product specification have been prescribed on the premise that our product is used for the purpose, under the condition and in the environment agreed upon between you and us. You are requested not to use our product deviating from such agreement.
4. Please keep the distance between transformer/coil and other components (refer to the standard IEC 950)
5. The moisture sensitivity level (MSL) of products is classified as level 1.

BPSD00060545 Series Specification

14 Graph:

BPSD000605451R8□00

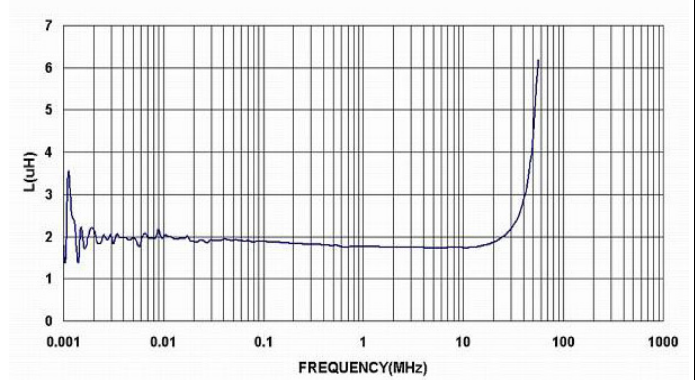
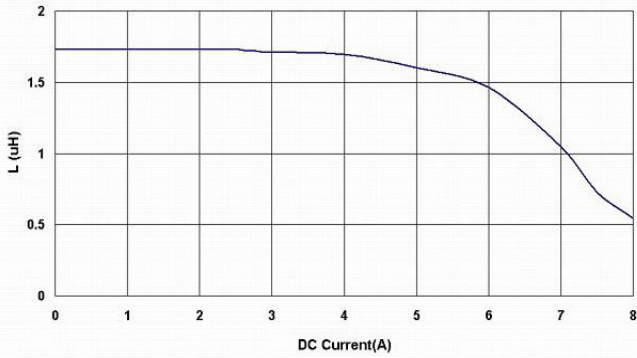

BPSD000605452R2□00

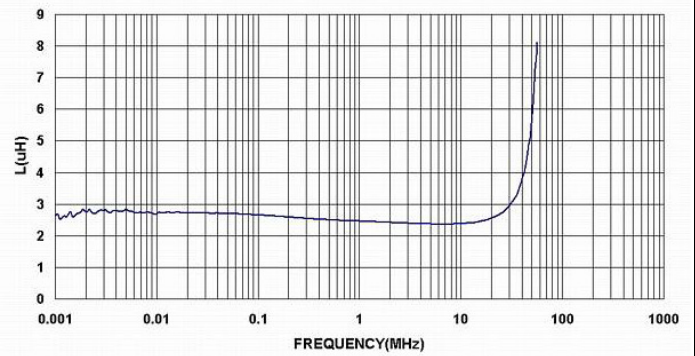
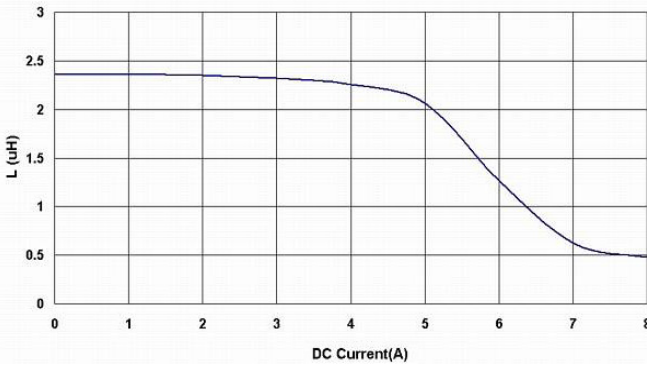

BPSD000605453R3□00

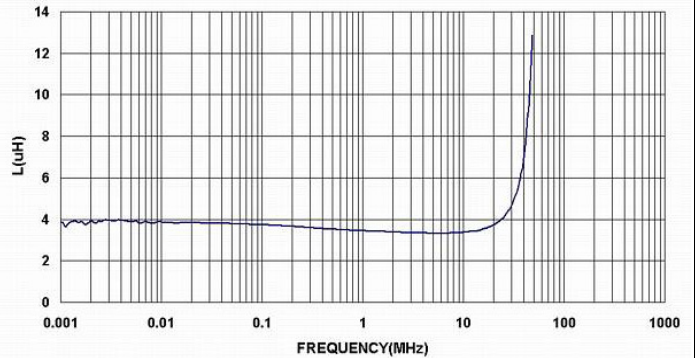

BPSD00060545222□00

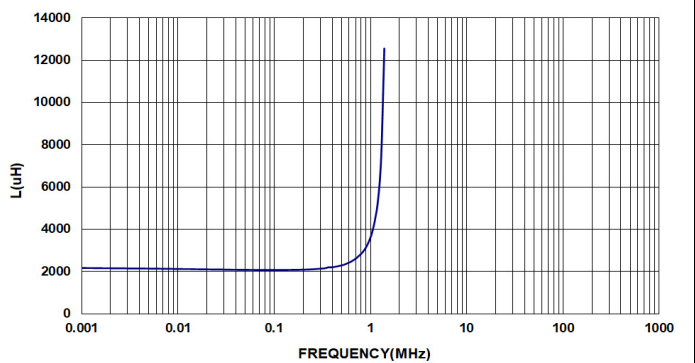
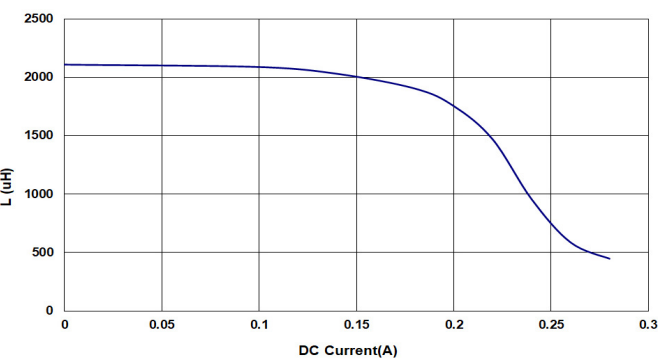

BPSD00060545 Series Specification

14 Graph:

BPSD000605454R7□00

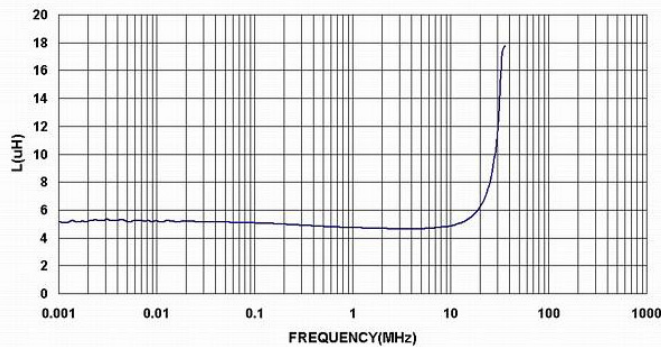
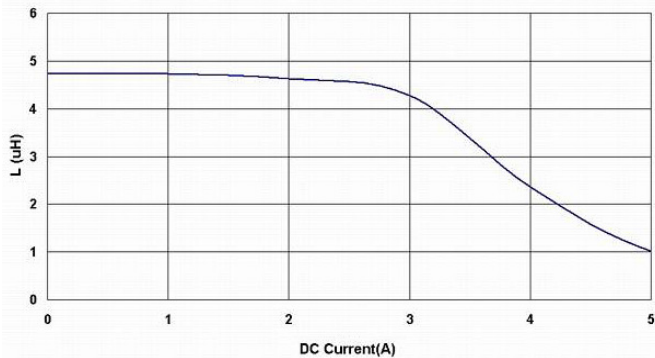

BPSD000605456R8□00

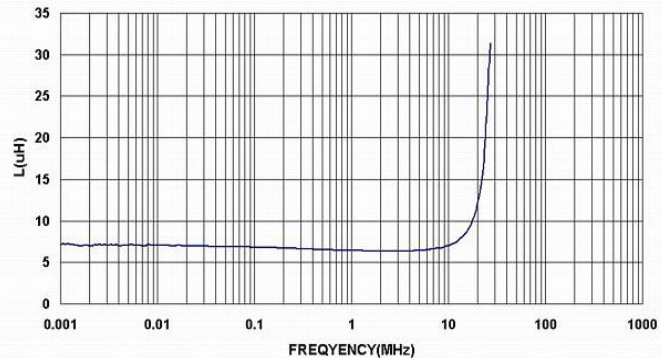
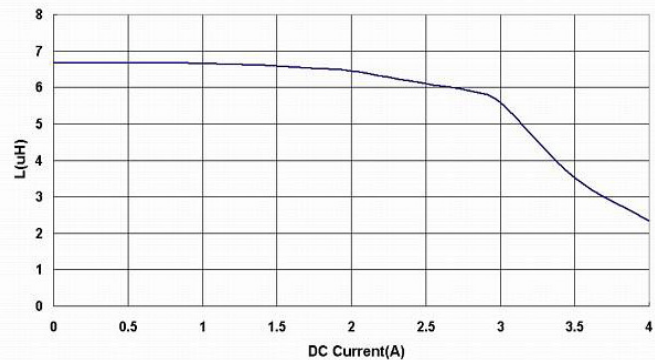

BPSD000605458R2□00

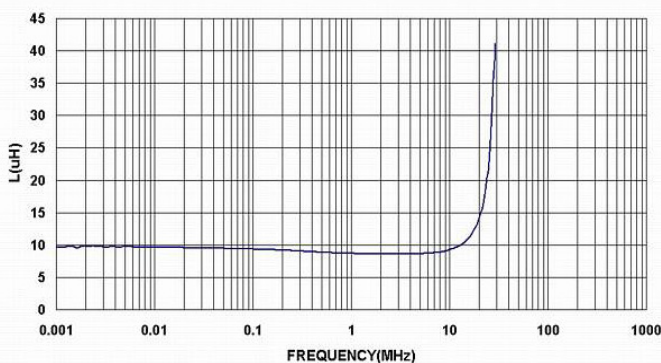

BPSD00060545100□00

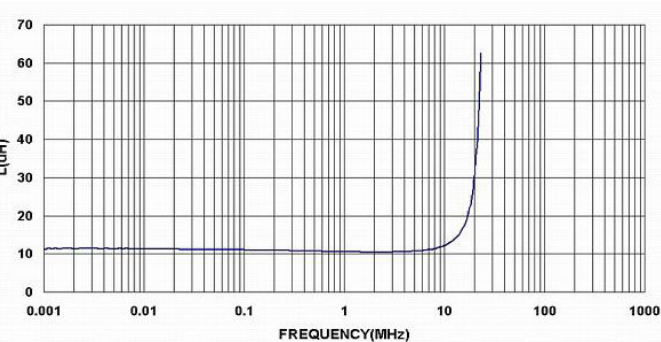
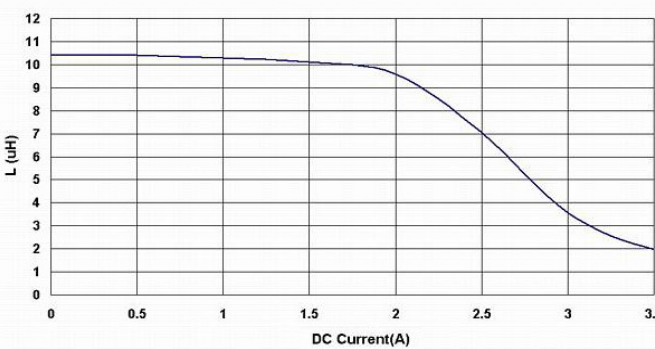

BPSD00060545 Series Specification

14 Graph:

BPSD00060545120□00

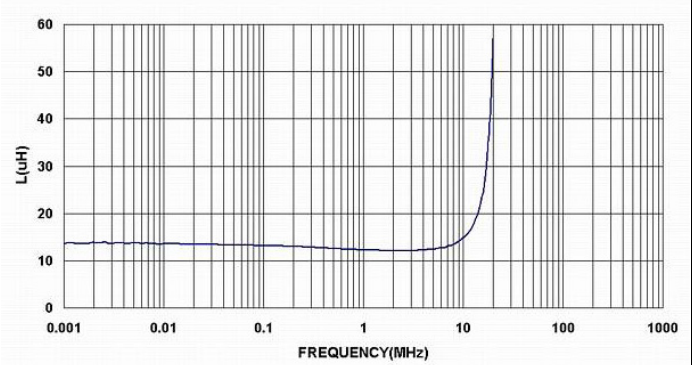
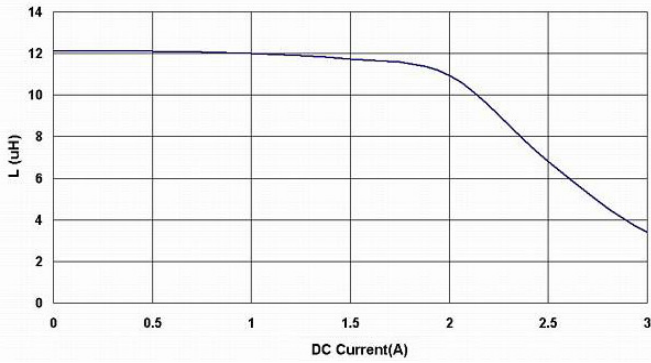

BPSD00060545150□00

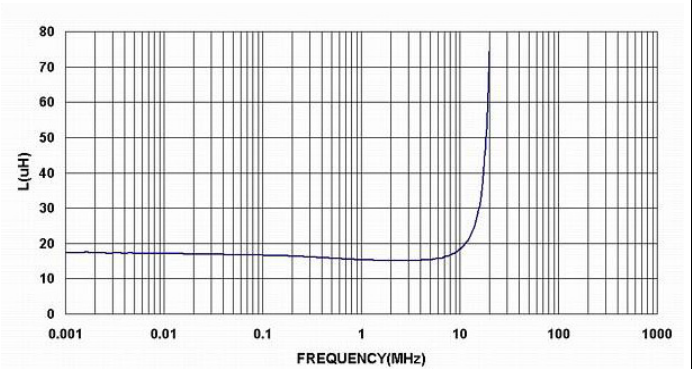
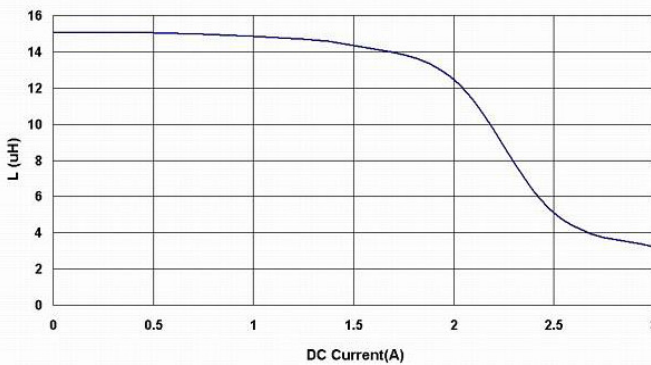

BPSD00060545180□00

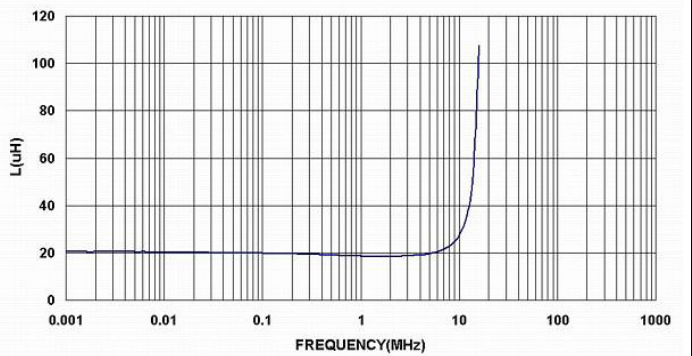
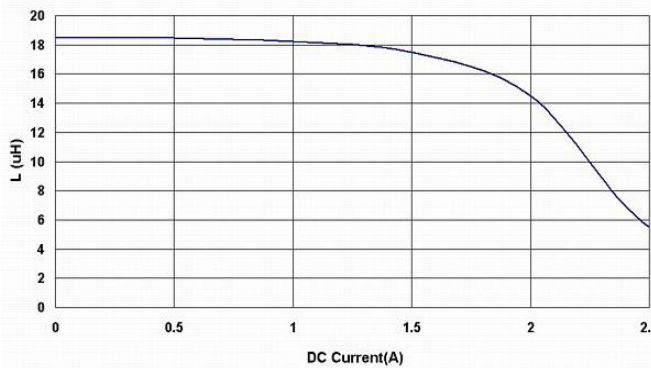

BPSD00060545220□00

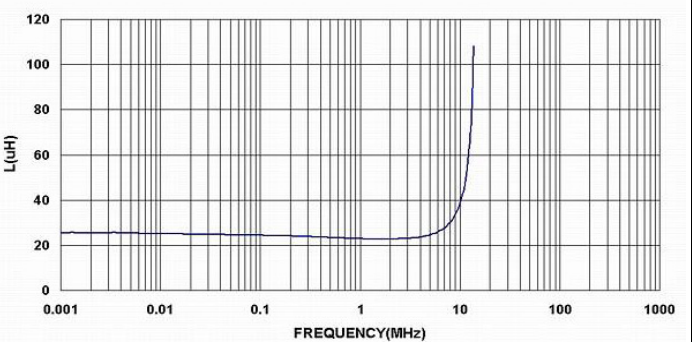
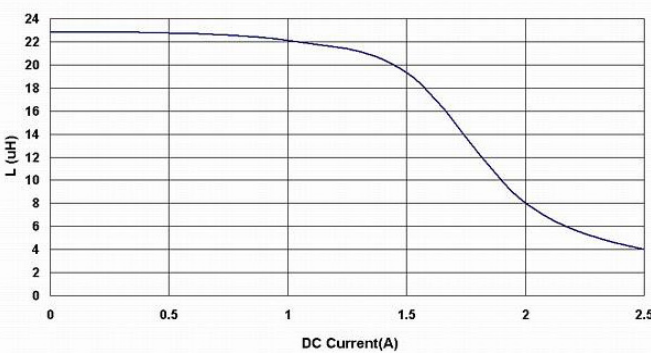

BPSD00060545 Series Specification

14 Graph:

BPSD00060545270□00

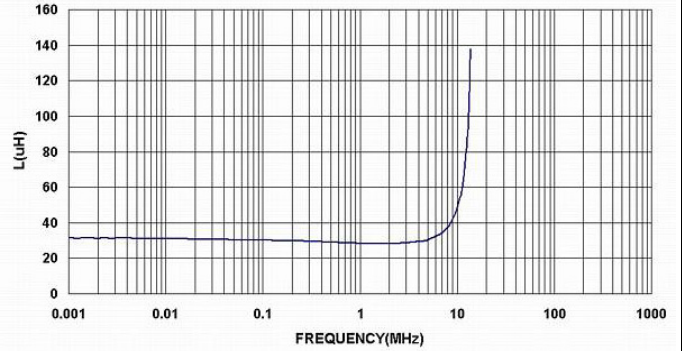
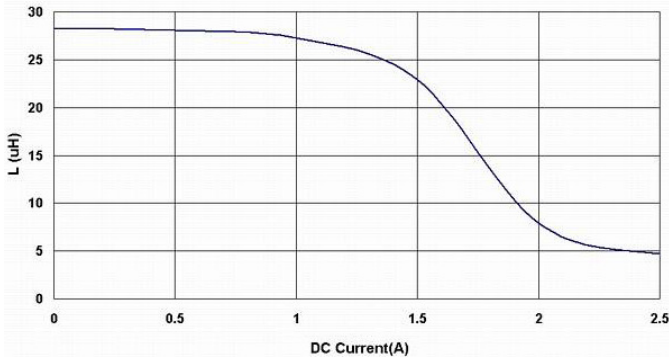

BPSD00060545330□00

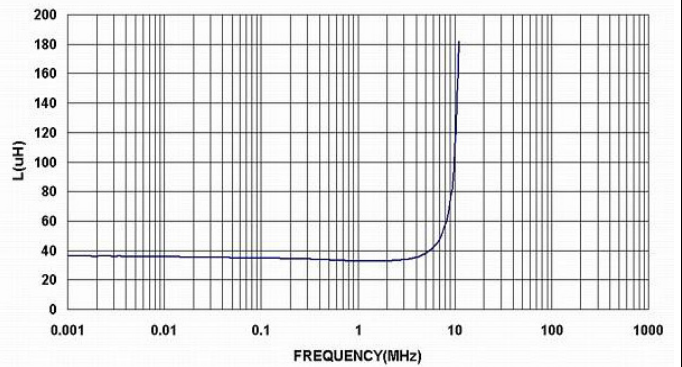
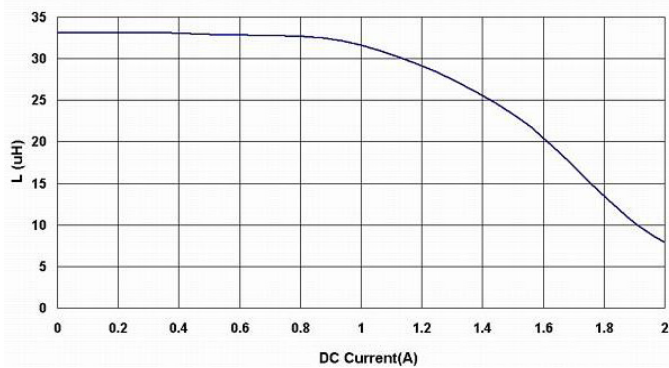

BPSD00060545390□00

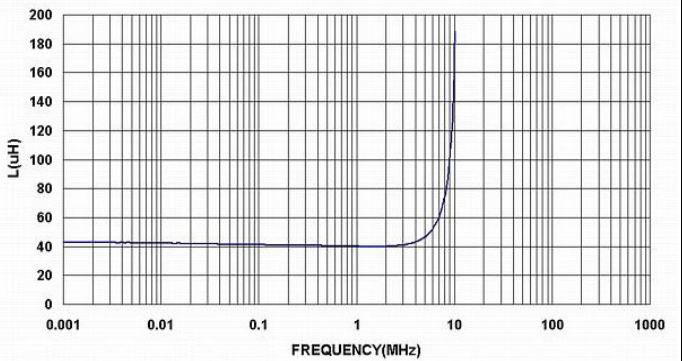
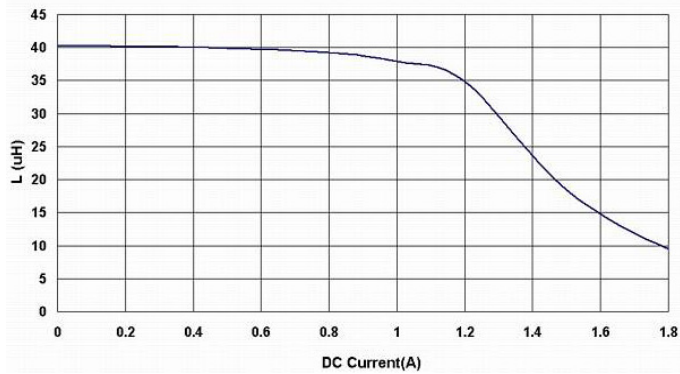

BPSD00060545470□00

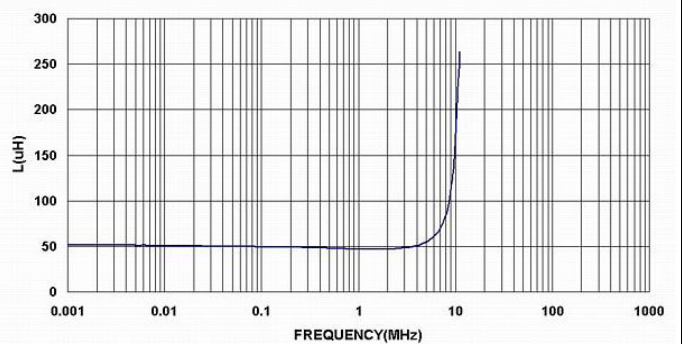
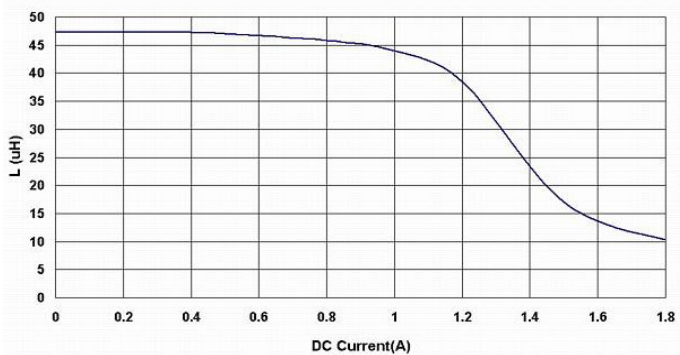

BPSD00060545 Series Specification

14 Graph:

BPSD00060545560□00

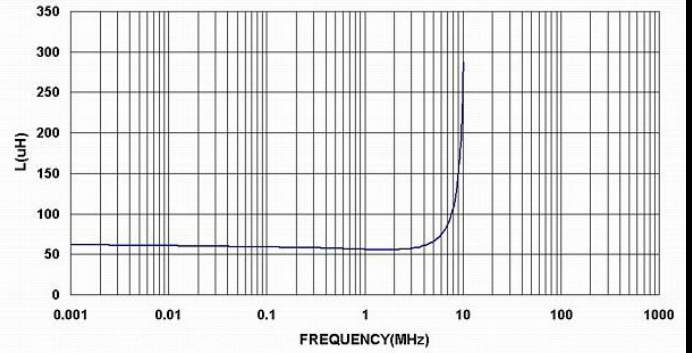
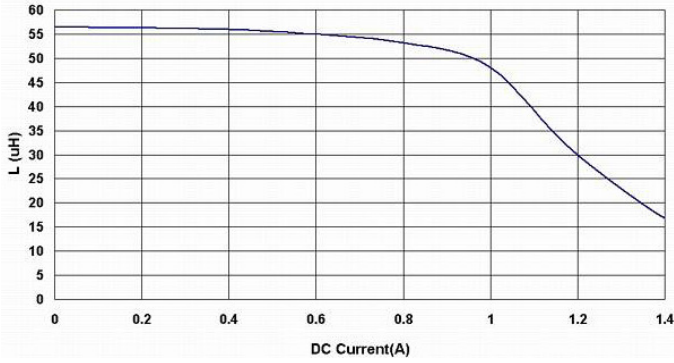

BPSD00060545680□00

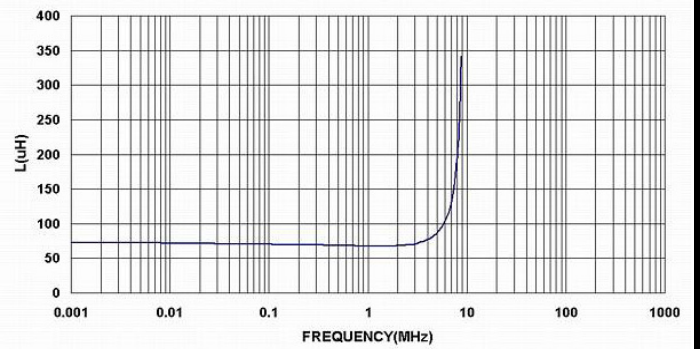
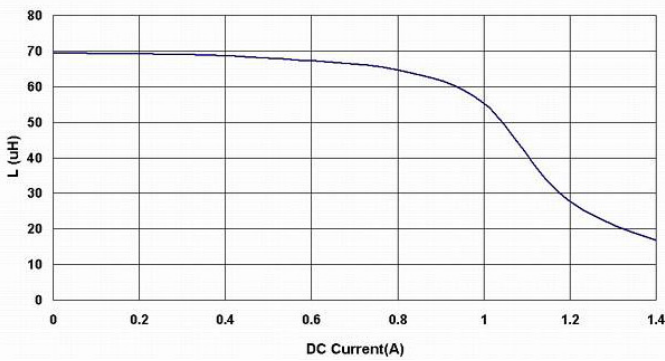

BPSD00060545820□00

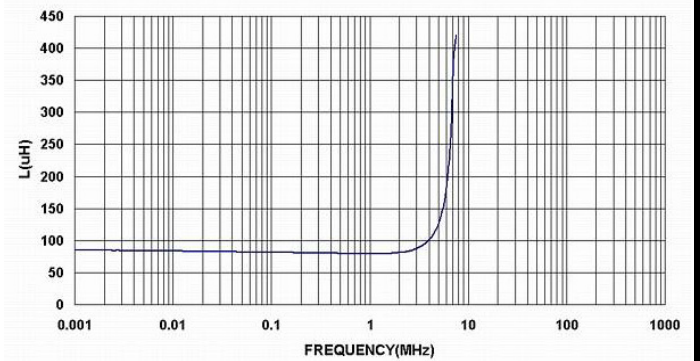
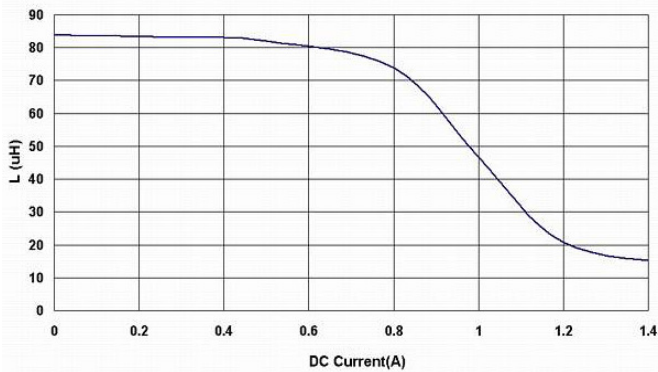

BPSD00060545101□00

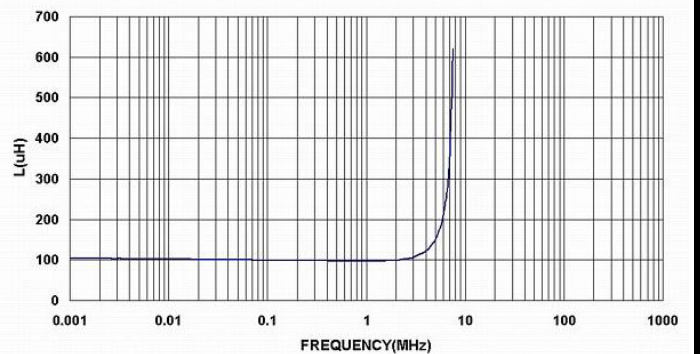
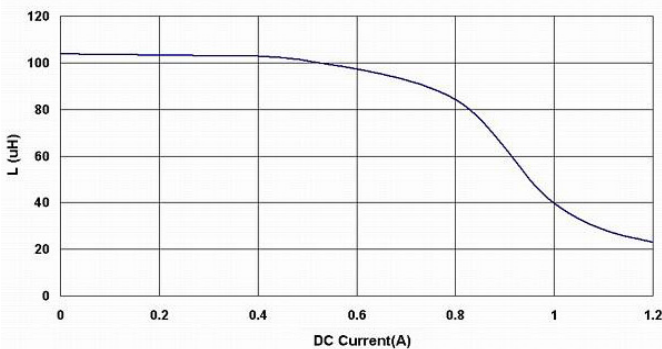

BPSD00060545 Series Specification

14 Graph:

BPSD00060545121□00

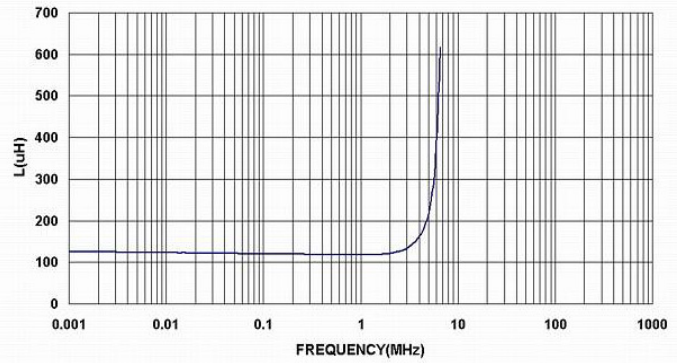
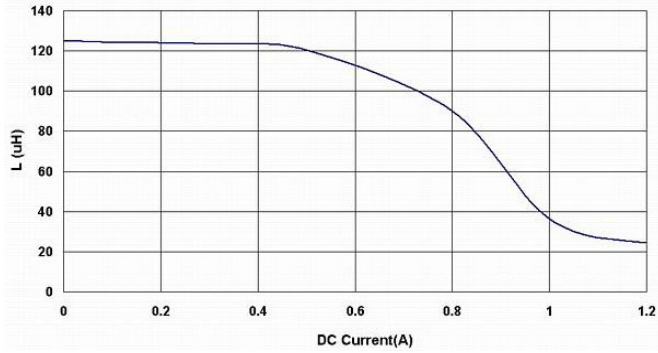

BPSD00060545151□00

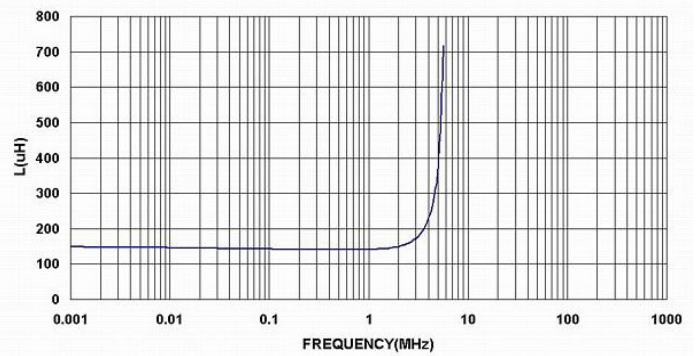
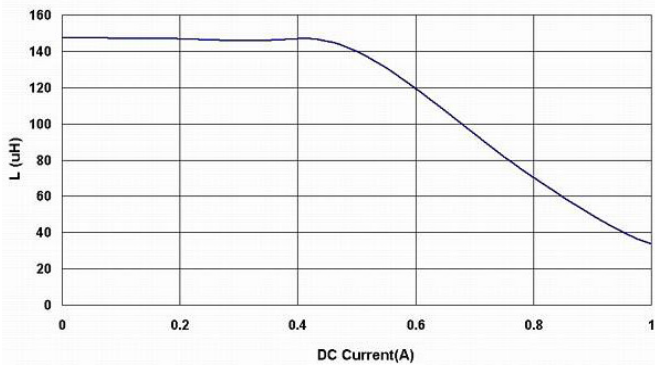

BPSD00060545181□00

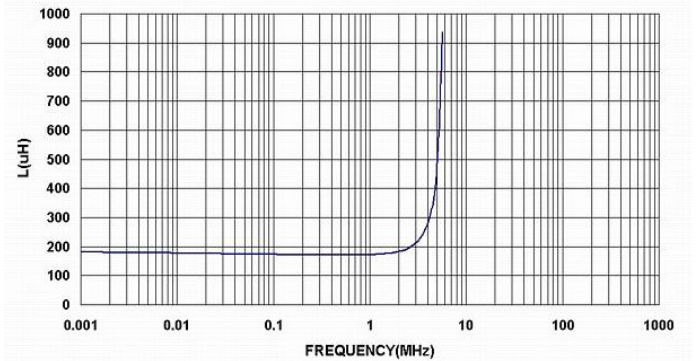
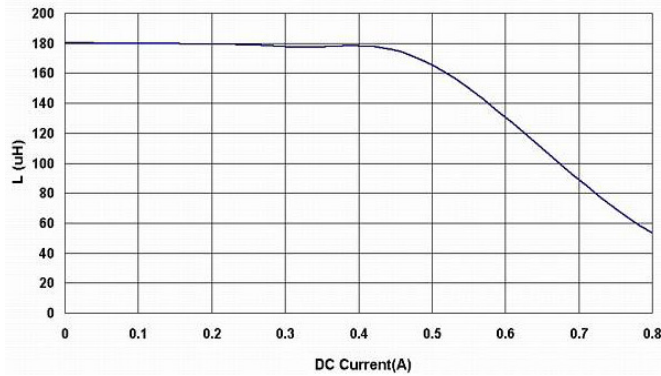

BPSD00060545221□00

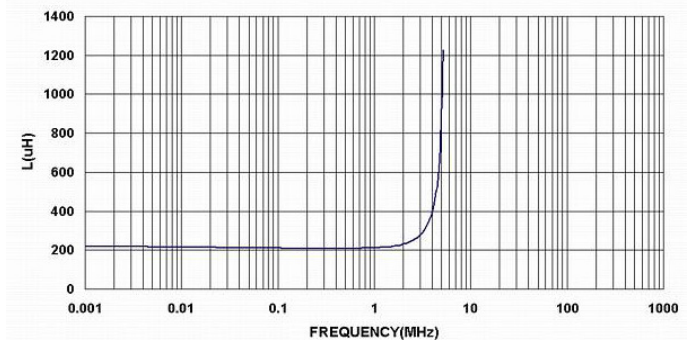
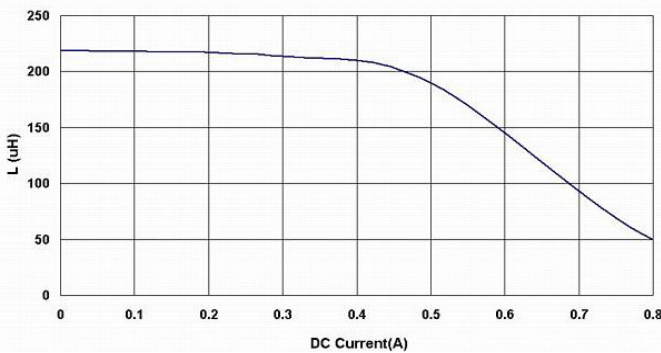

BPSD00060545 Series Specification

14 Graph:

BPSD00060545271□00

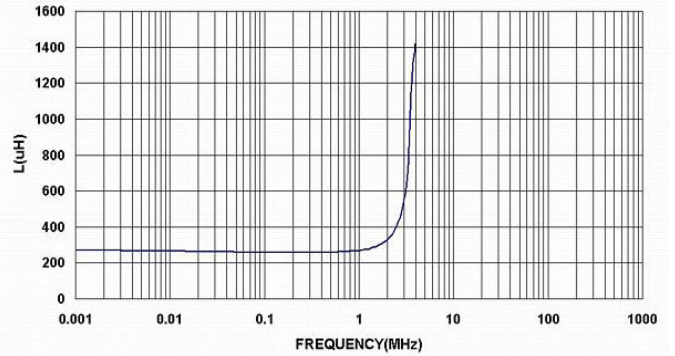
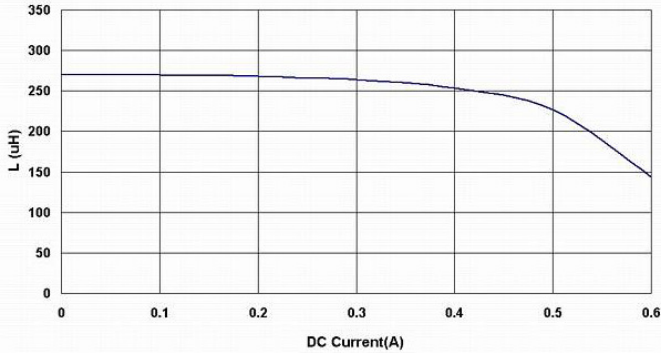

BPSD00060545331□00

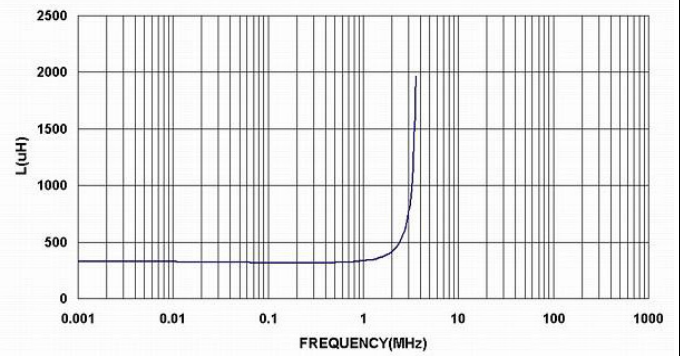
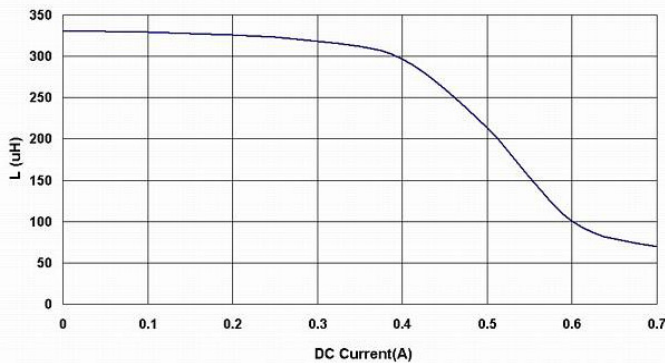

BPSD00060545391□00

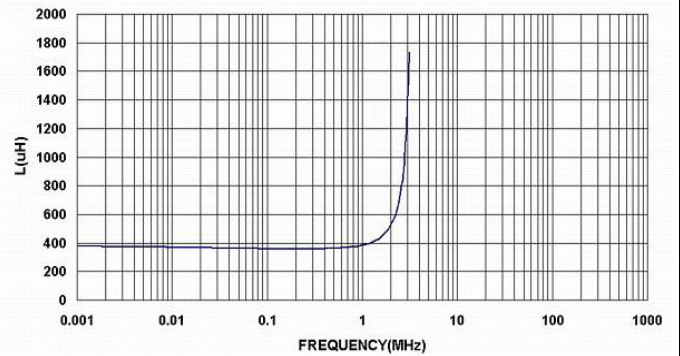
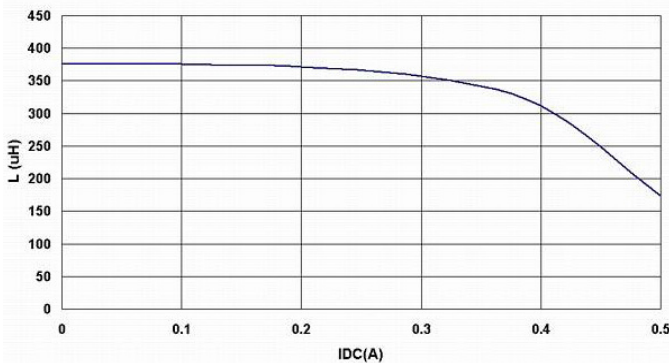

BPSD00060545471□00

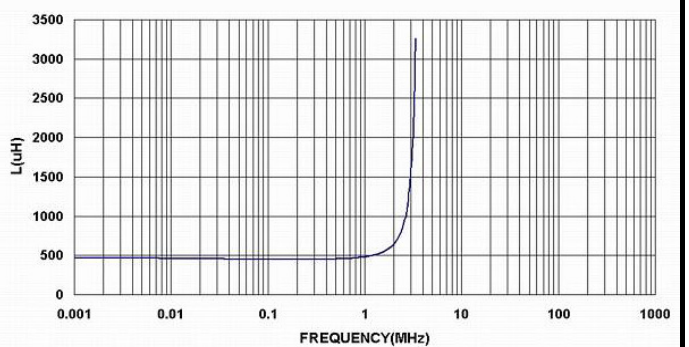
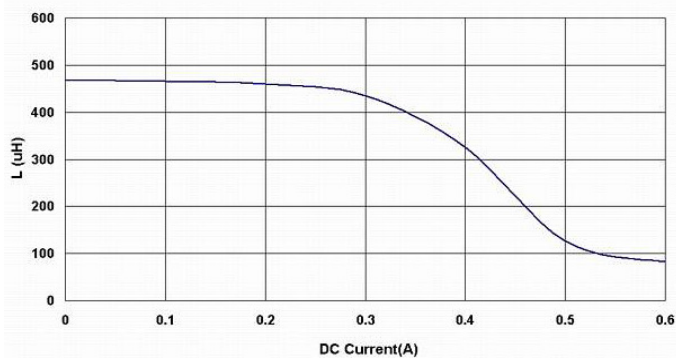

BPSD00060545 Series Specification

14 Graph:

BPSD00060545561□00

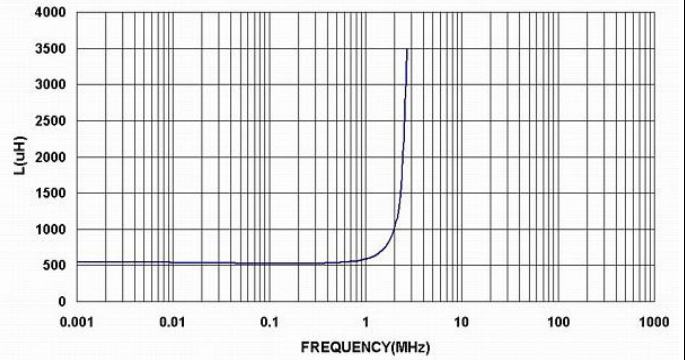
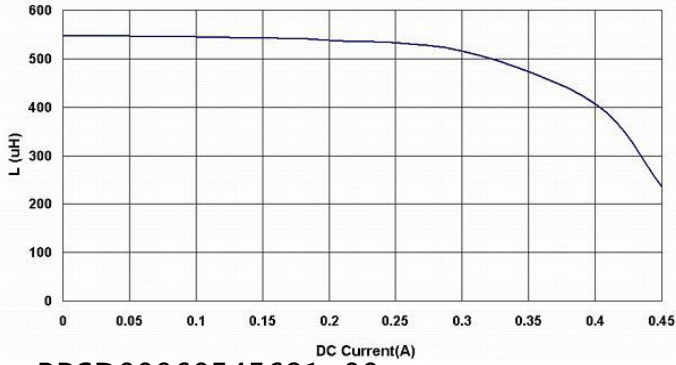

BPSD00060545681□00

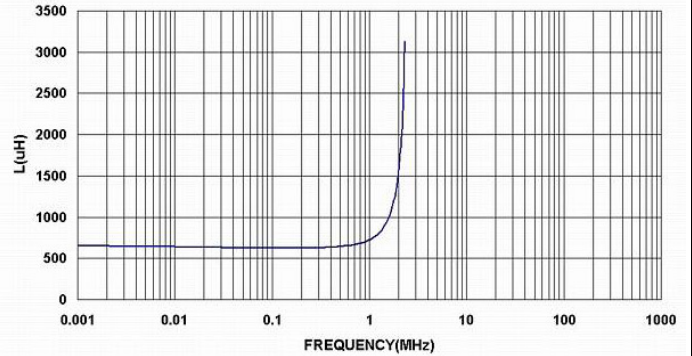
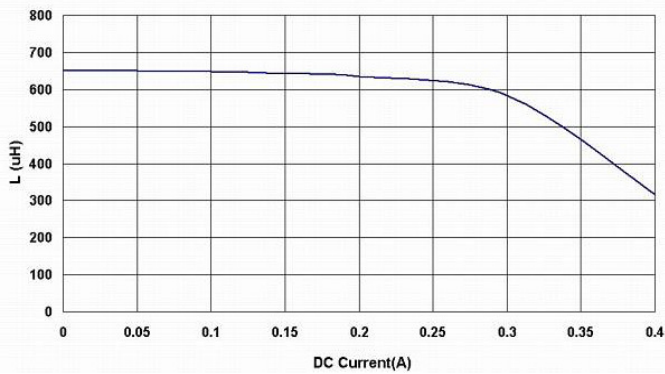

BPSD00060545821□00

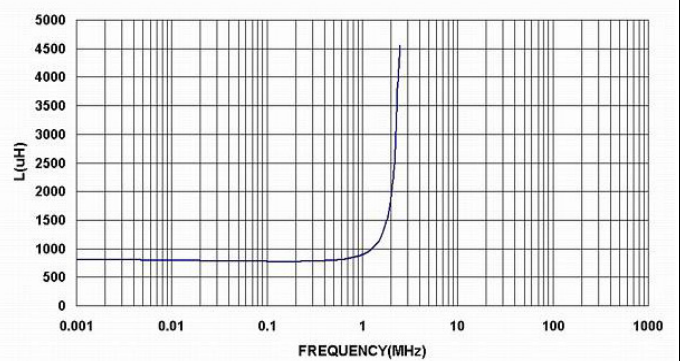
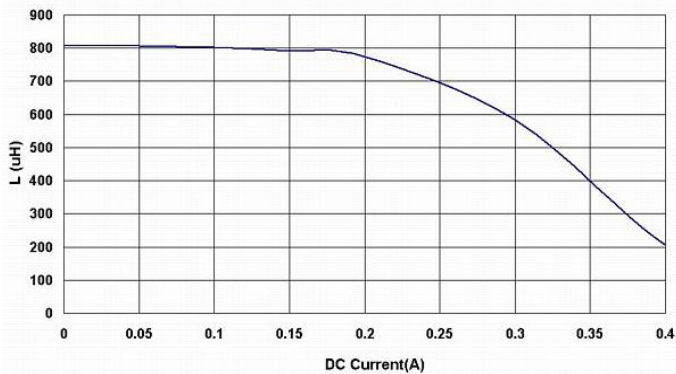

BPSD00060545102□00

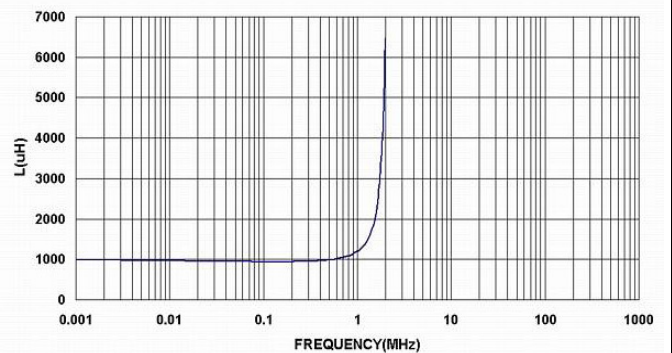
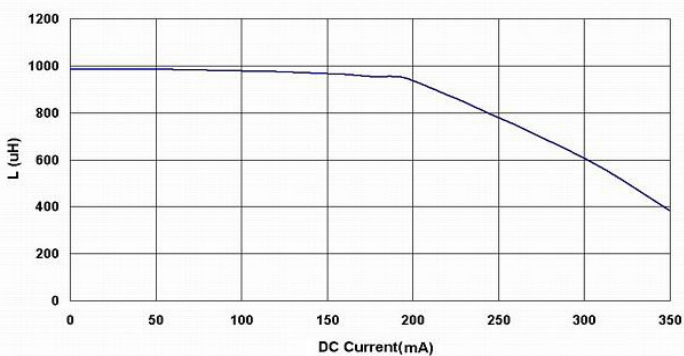

BPSD00060545 Series Specification

14 Graph:

BPSD00060545152□00

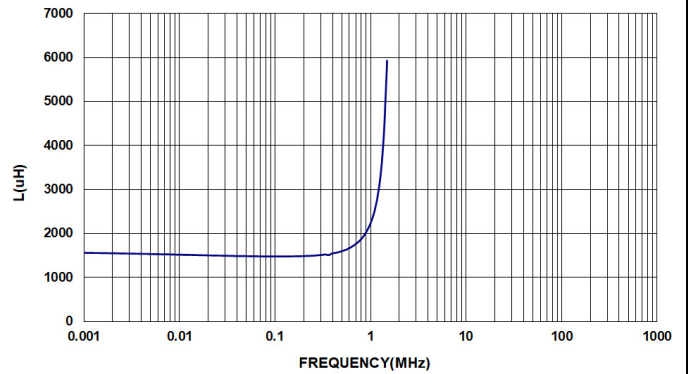
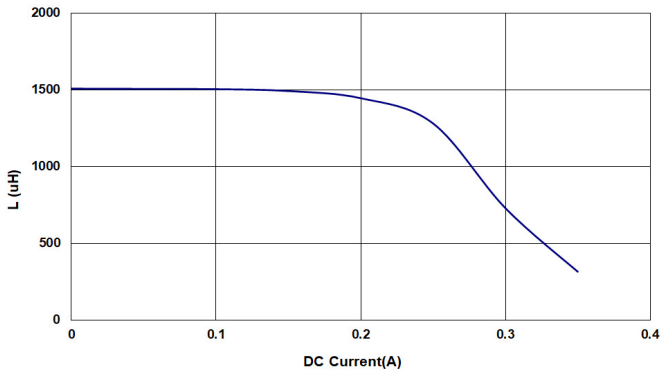

BPSD00060545182□00

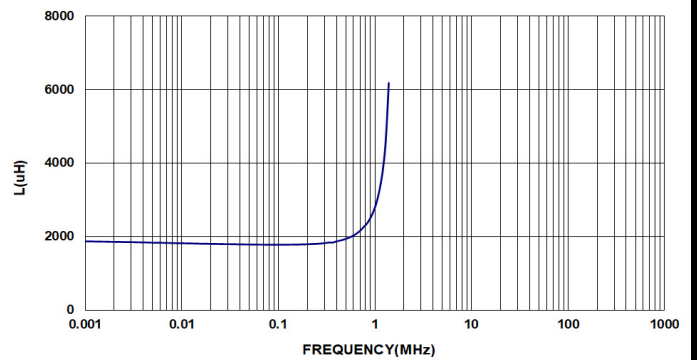
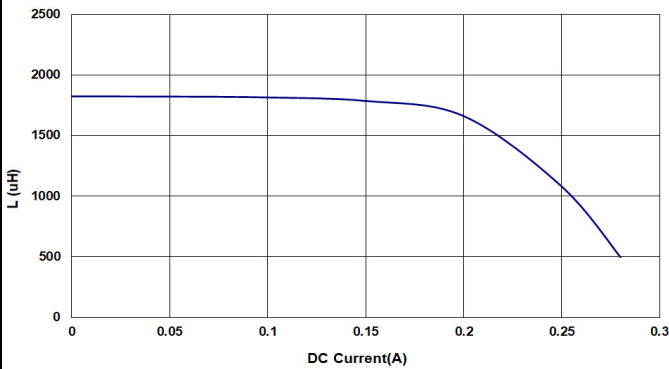

BPSD00060545202□00

