

# Power Inductor

## BPAL Series



### Overview

Power inductors are passive electronic components used in various circuits to store energy in a magnetic field when electrical current flows through them. They are critical in filtering, energy storage, and noise suppression in power electronic systems. They are designed to handle higher currents and are optimized for minimal power loss and thermal efficiency.

### Benefits

1. Low Rdc and high saturation current for portable DC to DC converter line
2. High magnetic shielding construction provides high resolution for EMC protection
3. Support lead-free soldering

### Applications

1. Notebook PC
2. Set top box, SSD
3. LCD TV, LCD displays
4. Portable communication device
5. DC/DC converters
6. Networking

### Product Information

Series	L (mm)	W(mm)	T (mm)	Inductance (μH)
BPAL	6.3	6.2	3.0	1 ~ 2200
	6.2	6.0	4.5	
	7.5	7.5	4.5	





## BPAL00060630 Series Specification

### 6 Electrical Characteristics:

Part No.	Inductance L( $\mu$ H)	Test Freq.	Resistance RDC( $\Omega$ )Max.	Rated DC Current		Tolerance	Marking
				Isat(A)	Irms(A)		
BPAL000606301R0□00	1.0	100kHz/0.25V	14m	3.59	5.32	M,T	1R0
BPAL000606301R5□00	1.5	100kHz/0.25V	16m	2.93	4.45	T	1R5
BPAL000606302R2□00	2.2	100kHz/0.25V	20m	2.42	4.13	T	2R2
BPAL000606303R3□00	3.3	100kHz/0.25V	26m	1.89	3.54	M,T	3R3
BPAL000606303R6□00	3.6	100kHz/0.25V	26m	1.89	3.54	T	3R6
BPAL000606304R7□00	4.7	100kHz/0.25V	33m	1.66	3.03	T	4R7
BPAL000606306R2□00	6.2	100kHz/0.25V	39m	1.45	2.69	T	6R2
BPAL000606306R8□00	6.8	100kHz/0.25V	41m	1.40	2.60	M,T	6R8
BPAL000606308R2□00	8.2	100kHz/0.25V	49m	1.20	2.50	M,T	8R2
BPAL00060630100□00	10	100kHz/0.25V	59m	1.14	2.25	M,T	100
BPAL00060630120□00	12	100kHz/0.25V	63m	1.04	2.12	M,T	120
BPAL00060630150□00	15	100kHz/0.25V	75m	0.93	2.04	M,T	150
BPAL00060630180□00	18	100kHz/0.25V	89m	0.85	1.86	M,T	180
BPAL00060630220□00	22	100kHz/0.25V	0.115	0.77	1.58	M,T	220
BPAL00060630270□00	27	100kHz/0.25V	0.144	0.70	1.35	M,T	270
BPAL00060630330□00	33	100kHz/0.25V	0.168	0.63	1.19	M,T	330
BPAL00060630390□00	39	100kHz/0.25V	0.180	0.58	1.16	M,T	390
BPAL00060630470□00	47	100kHz/0.25V	0.225	0.53	1.05	M,T	470
BPAL00060630560□00	56	100kHz/0.25V	0.264	0.48	0.97	M,T	560
BPAL00060630680□00	68	100kHz/0.25V	0.324	0.44	0.87	M,T	680
BPAL00060630820□00	82	100kHz/0.25V	0.396	0.40	0.76	M,T	820
BPAL00060630101□00	100	100kHz/0.25V	0.498	0.36	0.69	M,T	101
BPAL00060630151□00	150	100kHz/0.25V	0.738	0.31	0.52	M,T	151
BPAL00060630221□00	220	100kHz/0.25V	1.400	0.28	0.45	M,T	221
BPAL00060630331□00	330	100kHz/0.25V	2.100	0.18	0.42	M,T	331

**NOTE: tolerance M=±20%, T=±30%**

1. Isat : Based on inductance change ( $\Delta$ L/Lo : drop 30% Max.) @ambient temperature 25°C
2. Irms : Based on temperature rise ( $\Delta$ T : 40°C Typ.)

## BPAL00060630 Series Specification

### 6.1 Construction:

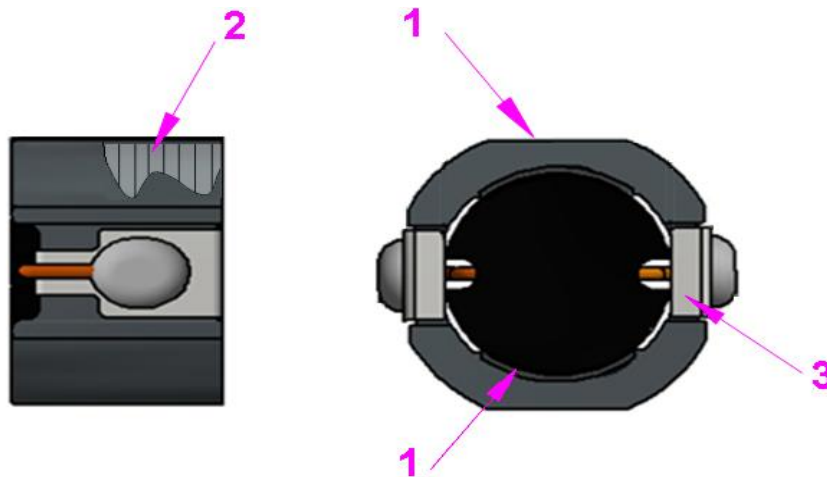

### 6.2 Material List:

NO.	ITEM	DESCRIPTION & TYPE
1	CORE	FERRITE
2	Wire	Magnet Wire (P180)
3	Terminal	Terminal Copper

## BPAL00060630 Series Specification

### ELECTRICAL

TEST ITEM	SPECIFICATION	TEST DETAILS
Insulation resistance	There shall be no other damage or problems.	DC 100V voltage shall be applied across this sample of top surface and the terminal. The insulation resistance shall be more than $1 \times 10^8 \Omega$ .
Dielectric withstand voltage	There shall be no other damage or problems.	AC 100V voltage shall be applied for 1 minute across the top surface and the terminal of this sample
Temperature characteristics	$\Delta L/L_{20^\circ\text{C}} \leq \pm 10\%$ $0 \sim 2000 \text{ ppm}/^\circ\text{C}$	The test shall be performed after the sample has stabilized in an ambient temperature of $-20$ to $+85^\circ\text{C}$ , and the value calculated based on the value applicable in a normal temperature and normal humidity shall be $\Delta L/L_{20^\circ\text{C}} \leq \pm 10\%$ .

### MECHANICAL

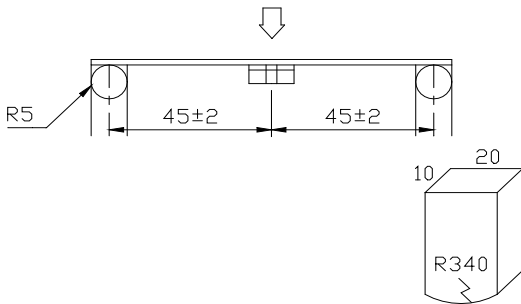
TEST ITEM	SPECIFICATION	TEST DETAILS
Substrate bending	$\Delta L/L_0 \leq \pm 10\%$  There shall be no mechanical damage or electrical damage.	The sample shall be soldered onto the printed circuit board in figure 1 and a load applied until the figure in the arrow direction is made approximately 3mm. (keep time 30 seconds) PCB dimension shall be the page 7/9  F(Pressurization)   PRESSURE ROD figure-1

## BPAL00060630 Series Specification

### MECHANICAL

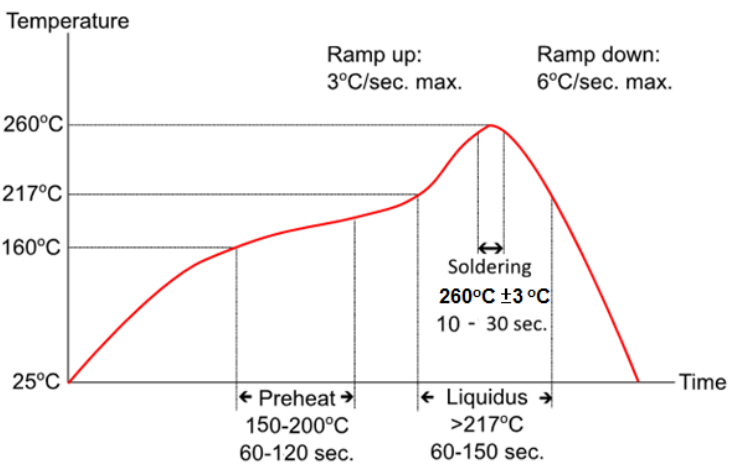
TEST ITEM	SPECIFICATION	
Vibration	$\Delta L/L_0 \leq \pm 10\%$  There shall be no mechanical damage.	The sample shall be soldered onto the printed circuit board and when a vibration having an amplitude of 1.52mm and a frequency of from 10 to 55Hz/1 minute repeated should be applied to the 3 directions (X,Y,Z) for 2 hours each. (A total of 6 hours)
Solderability	New solder More than 90%	Flux (rosin, isopropyl alcohol{JIS-K-1522}) shall be coated over the whole of the sample before hard, the sample shall then be preheated for about 2 minutes in a temperature of 130~150°C and after it has been immersed to a depth 0.5mm below for 3±0.2 seconds fully in molten solder M705 with a temperature of 245±5°C.  More than 90% of the electrode sections shall be covered with new solder smoothly when the sample is taken out of the solder bath.
Resistance to Soldering heat (reflow soldering)	There shall be no damage or problems.	<p style="text-align: center;"><b>Temperature profile of reflow soldering</b></p>  <p>The specimen shall be passed through the reflow oven with the condition shown in the above profile for 1 time. The specimen shall be stored at standard atmospheric conditions for 1 hour, after which the measurement shall be made.</p>

## BPAL00060630 Series Specification

### ENVIRONMENT CHARACTERISTICS

TEST ITEM	SPECIFICATION																
High temperature storage	$\Delta L/Lo \leq \pm 10\%$  There shall be no mechanical damage.	The sample shall be left for 96±4 hours in an atmosphere with a temperature of 125°C and a normal humidity.  Upon completion of the measurement shall be made after the sample has been left in a normal temperature and normal humidity for 1 hour.															
Low temperature storage	$\Delta L/Lo \leq \pm 10\%$  There shall be no mechanical damage.	The sample shall be left for 96±4 hours in an atmosphere with a temperature of -40±2°C.  Upon completion of the test, the measurement shall be made after the sample has been left in a normal temperature and normal humidity for 1 hour.															
Change of temperature	$\Delta L/Lo \leq \pm 10\%$  There shall be no other damage of problems	The sample shall be subject to 5 continuous cycles, such as shown in the table 2 below and then it shall be subjected to standard atmospheric conditions for 1 hour, after which measurement shall be made. <div style="text-align: center; margin-top: 10px;"> <p>table 2</p> <table border="1"> <thead> <tr> <th></th> <th>Temperature</th> <th>Duration</th> </tr> </thead> <tbody> <tr> <td>1</td> <td>-40±2°C (Thermostat No.1)</td> <td>30 min.</td> </tr> <tr> <td>2</td> <td>Standard atmospheric</td> <td>No.1→No.2</td> </tr> <tr> <td>3</td> <td>125°C (Thermostat No.2)</td> <td>30 min.</td> </tr> <tr> <td>4</td> <td>Standard atmospheric</td> <td>No.2→No.1</td> </tr> </tbody> </table> </div>		Temperature	Duration	1	-40±2°C (Thermostat No.1)	30 min.	2	Standard atmospheric	No.1→No.2	3	125°C (Thermostat No.2)	30 min.	4	Standard atmospheric	No.2→No.1
	Temperature	Duration															
1	-40±2°C (Thermostat No.1)	30 min.															
2	Standard atmospheric	No.1→No.2															
3	125°C (Thermostat No.2)	30 min.															
4	Standard atmospheric	No.2→No.1															
Moisture storage	$\Delta L/Lo \leq \pm 10\%$  There shall be no mechanical damage.	The sample shall be left for 96±4 hours in a temperature of 40±2°C and a humidity(RH) of 90~95%.  Upon completion of the test, the measurement shall be made after the sample has been left in a normal temperature and normal humidity more than 1 hour.															
<b>Test conditions :</b>  The sample shall be reflow soldered onto the printed circuit board in every test.																	

**BPAL00060630 Series Specification**

**7 Packaging:**

**7.1 Packaging -Cover Tape**

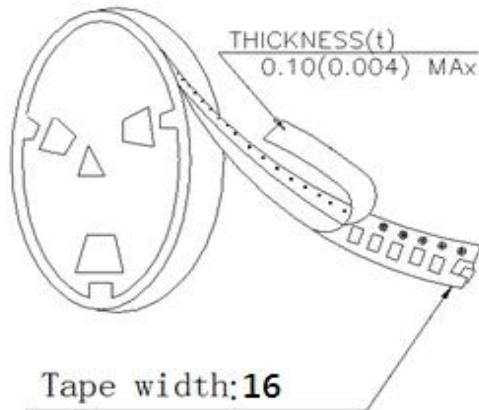

**7.2 Packaging Quantity**

TYPE	PCS/REEL
BPAL00060630	1500

**7.3 Reel Dimensions**

Unit : mm

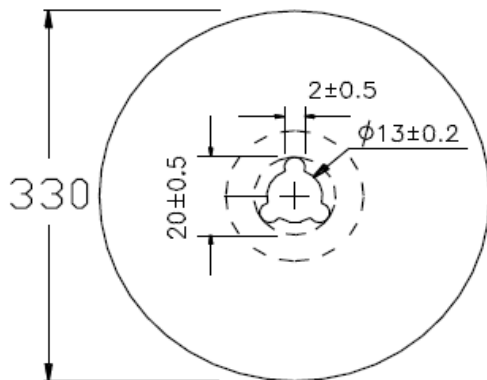

## BPAL0060630 Series Specification

### 7 Packaging:

#### 7.4 Tape Dimensions in mm

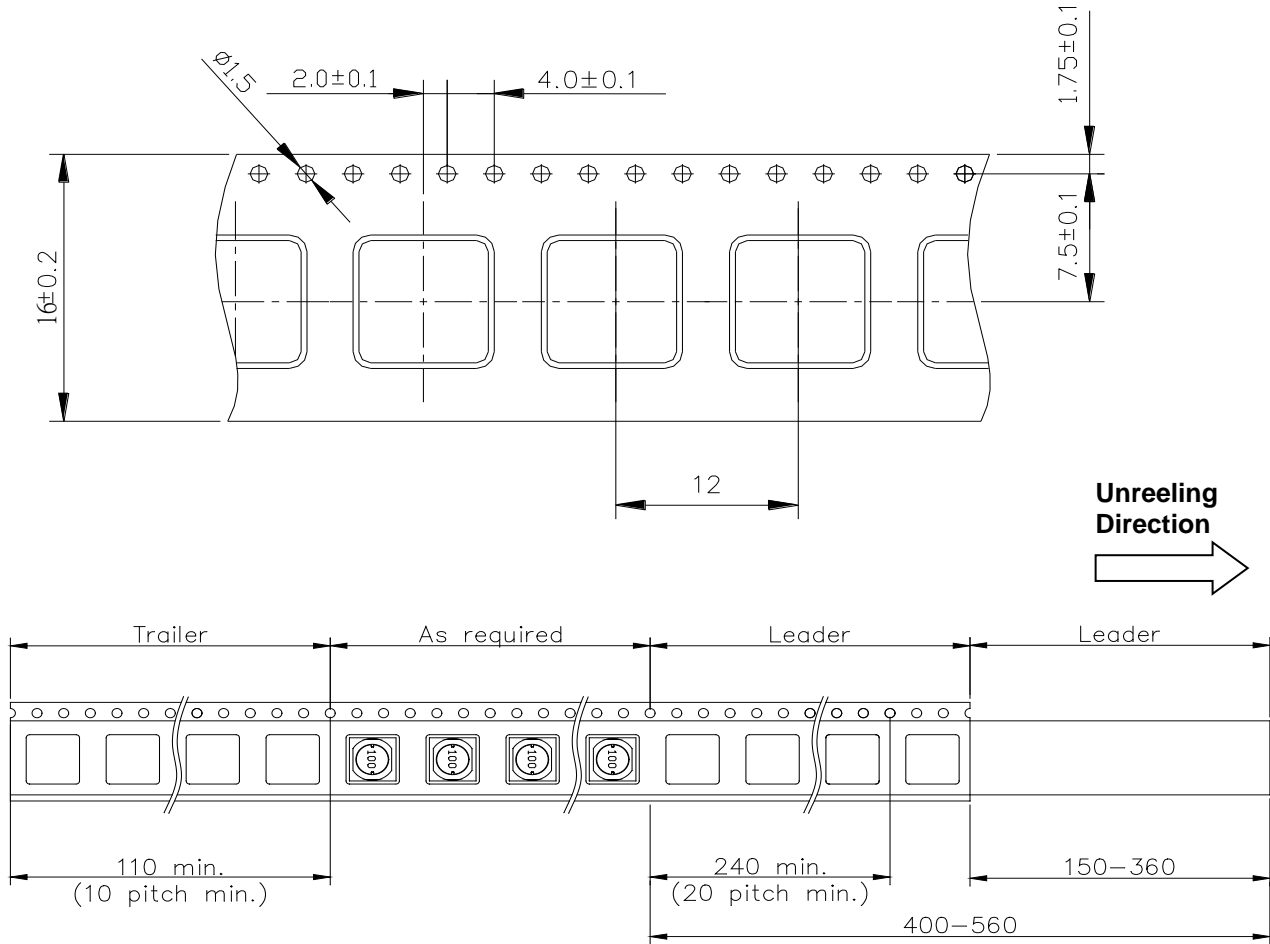

Unreeling  
Direction

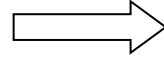

### 8 Recommended Land Pattern:

(STANDARD PATTERN) Unit : mm

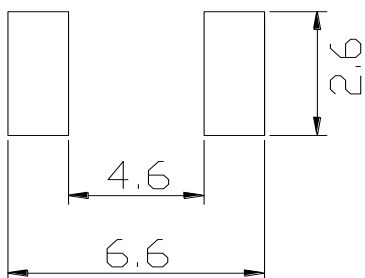

## BPAL00060630 Series Specification

### 9 Note:

1. Please make sure that your product has been evaluated and confirmed against your specifications when our product is mounted to your product.
2. Do not knock or drop.
3. All the items and parameters in this product specification have been prescribed on the premise that our product is used for the purpose, under the condition and in the environment agreed upon between you and us. You are requested not to use our product deviating from such agreement.
4. Please keep the distance between transformer/coil and other components (refer to the standard IEC 950)
5. The moisture sensitivity level (MSL) of products is classified as level 1.